

Hybrid System Overview

Overview Prius is a Latin word meaning “to go before.” Toyota chose this name because the Prius vehicle is the predecessor of cars to come. Rapid population growth and economic development in recent decades have resulted in a sharp increase in fossil fuel consumption on a global scale. Faced with the challenges to create an earth-friendly vehicle, Toyota has produced the world’s first mass produced hybrid automobile.

The hybrid system is the wave of the future, and now there are more incentives to purchase one. Owners of the Prius, or any other hybrid gas-and-electric vehicle, may be eligible for a federal income tax deduction. According to the Internal Revenue Service, hybrid vehicles qualify for a long-standing tax deduction that applies to vehicles powered by clean-burning fuels. The policy allows a one-time deduction, which can be claimed by the consumer for the year the car was first put in use.

In its simplest form, a hybrid system combines the best operating characteristics of an internal combustion engine and an electric motor. More sophisticated hybrid systems, such the Toyota Hybrid System, recover energy otherwise lost to heat in the brakes and use it to supplement the power of its fuel-burning engine. These sophisticated techniques allow the Toyota Hybrid System to achieve superior fuel efficiency and a massive reduction in CO₂.

When the Prius was first released, it was selected as the world’s best-engineered passenger car for 2001. The car was chosen because it is the first hybrid vehicle that seats four to five people plus their luggage, and it is one of the most economical and environmentally friendly vehicles available. Then in 2004, the second generation Prius won the prestigious Motor Trend Car of the Year award and best-engineered vehicle of 2004.

The Toyota Hybrid System (THS) powertrain in the original Prius and the Toyota Hybrid System II (THS-II) powertrain in the second generation Prius both provide impressive EPA fuel economy numbers and extremely clean emissions:

THS (2001-2003 Prius)		THS-II (2004 & Later)	
City:	52 mpg	City:	60 mpg
Highway:	45 mpg	Highway:	51 mpg
SULEV		AT-PZEV	

- SULEV standards are about 75% more stringent than ULEV and nearly 90% cleaner than LEV for smog forming exhaust gases.
- SULEV vehicles will emit less than a single pound of hydrocarbons during 100,000 miles of driving (about the same as spilling a pint of gasoline).
- AT-PZEV vehicles use advanced technology capable of producing zero emissions during at least part of the vehicle’s drive cycle.

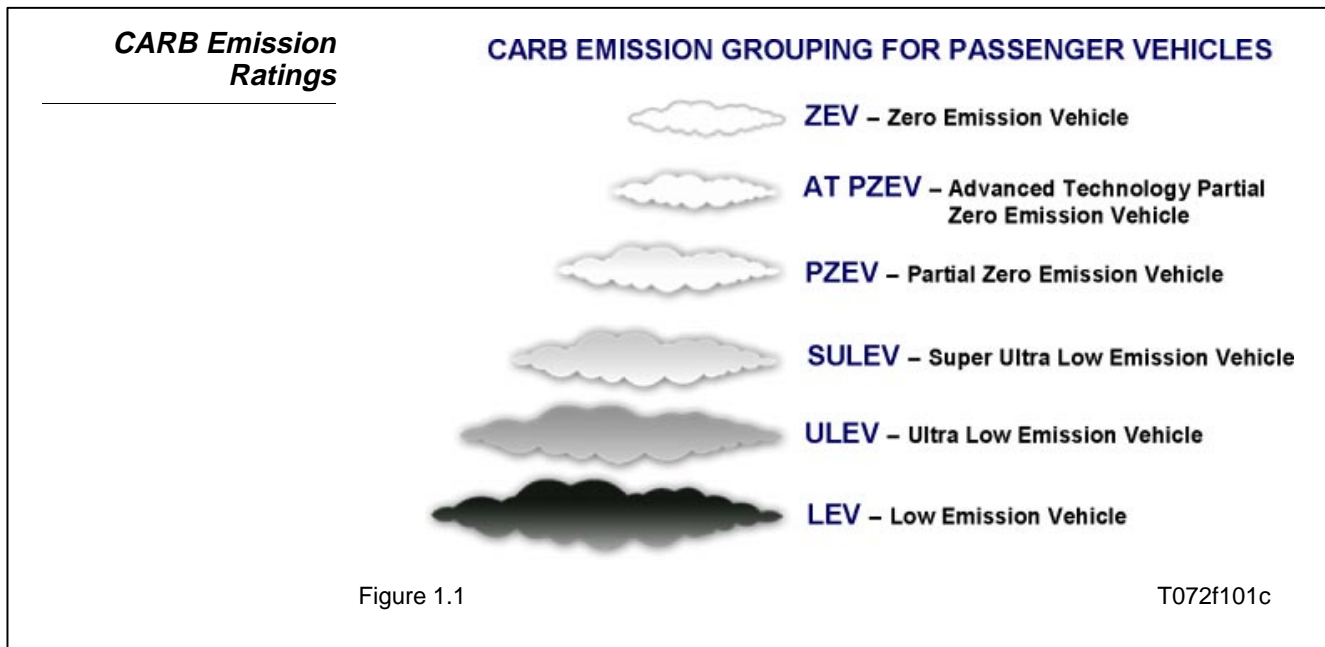

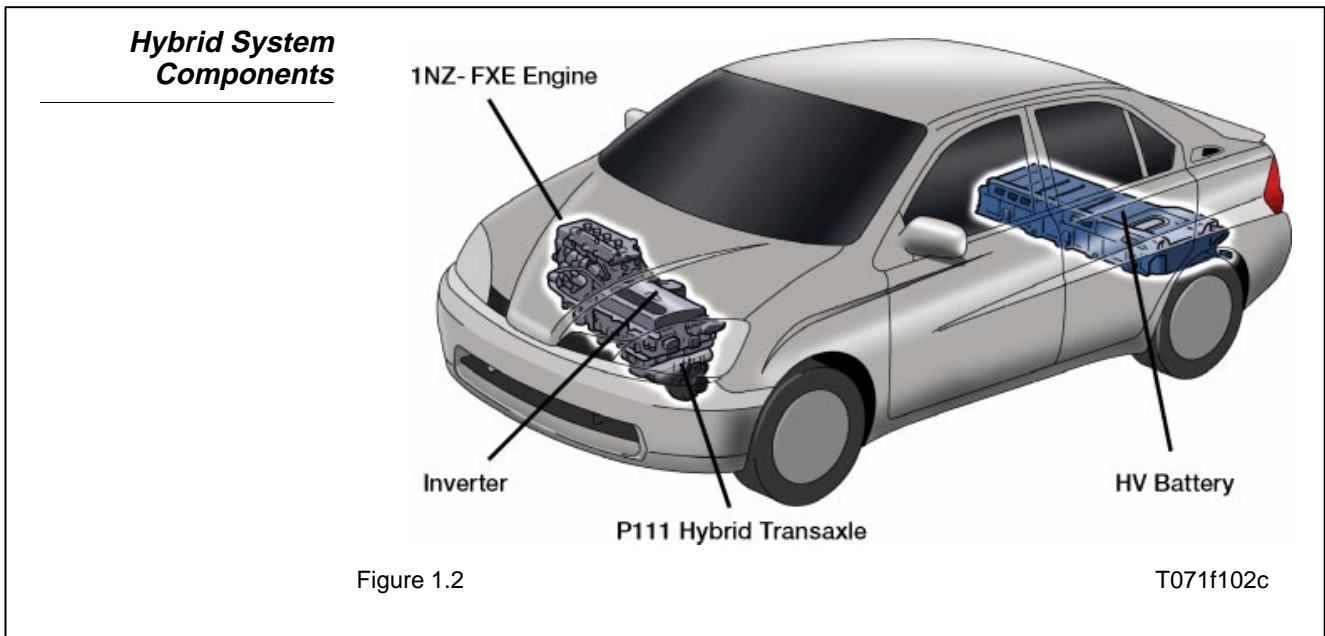

Hybrid System The main components of the hybrid system are:

- IC Engine
- Motor Generator 1 (MG1)
- Motor Generator 2 (MG2)
- Planetary Gear Set
- Inverter
- HV Battery
- HV ECU

IC Engine The 1NZ-FXE 1.5-liter gasoline engine employs VVT-i variable valve timing and ETCS-i electronic throttle control.

1NZ-FXE



Figure 1.3

T071f103p

Motor Generator 1 (MG1) Motor Generator 1 (MG1) operates as the control element for the power splitting planetary gear set. It recharges the HV battery and also supplies electrical power to drive Motor Generator 2 (MG2). MG1 effectively controls the continuously variable transmission function of the transaxle and operates as the engine starter.

***Motor Generator 1
(MG1)***

MG1 generates electrical power and starts the engine.



Figure 1.4

T071f104p

Motor Generator 2 (MG2) MG2 is used for motive force at low speeds and supplemental force at high speeds. It provides power assist to the engine output as needed and helps the vehicle achieve excellent dynamic performance. It also functions as a generator during regenerative braking.

Motor Generator 2 (MG2)

MG2 drives the vehicle.



Figure 1.5

T071f105p

Planetary Gear Unit The planetary gear unit is a power splitting device. MG1 is connected to the sun gear, MG2 is connected to the ring gear and the engine output shaft is connected to the planetary carrier. These components are used to combine power delivery from the engine and MG2, and to recover energy to the HV battery.

Planetary Gear Unit

A single Planetary Gear Unit splits the torque between MG1, MG2, and the engine.



Figure 1.6

T071f106p

Inverter Current between MG1, MG2 and the HV battery is controlled by the inverter. The inverter converts high-voltage battery DC to AC power, and it rectifies high-voltage AC from MG1 and MG2 to recharge the high-voltage battery.

Inverter Assembly

A device that converts the high-voltage DC (HV battery) into AC (MG1 and MG2) and vice versa.



Figure 1.7

T071f107p

HV Battery The battery stores power recovered by MG2 during regenerative braking and power generated by MG1. The battery supplies power to the electric motor when starting off or when additional power is required.

THS (2001-2003 Prius)	THS-II (2004 and later Prius)
38 Nickel-Metal Hydride modules	28 Nickel-Metal Hydride modules
Total voltage: 273.6V	Total voltage: 201.6V

HV Battery

Supplies electric power to MG2 during start-off, acceleration and uphill driving.

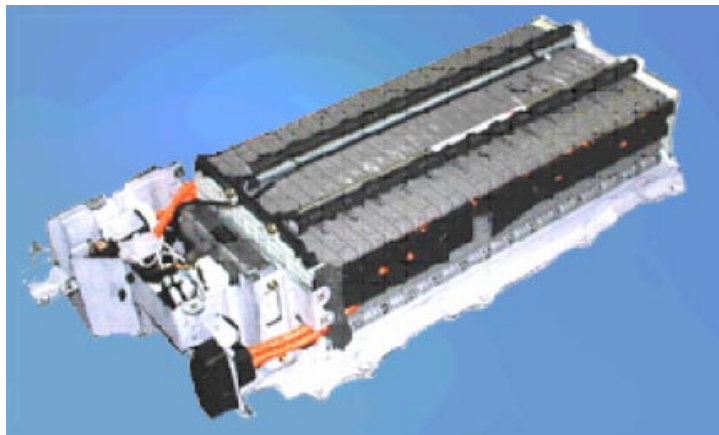

Figure 1.8

T071f108p

Hybrid System Control Modes

When starting off and traveling at low speeds, MG2 provides the primary motive force. The engine may start immediately if the HV battery State of Charge (SOC) is low. As speed increases above 15 to 20 mph the engine will start.

When driving under normal conditions, the engine's energy is divided into two paths; a portion drives the wheels and a portion drives MG1 to produce electricity. The HV ECU controls the energy distribution ratio for maximum efficiency.

During full acceleration, power generated by the engine and MG1 is supplemented by power from the HV battery. Engine torque combined with MG2 torque delivers the power required to accelerate the vehicle.

During deceleration or braking, the wheels drive MG2. MG2 acts as a generator for regenerative power recovery. The recovered energy from braking is stored in the HV battery pack.

Hybrid Control Modes

The hybrid system uses various modes to achieve the most efficient operation in response to the driving conditions. The following graphics review each of these modes.

Stopped If the vehicle is fully charged and it not moving, the engine may stop. The engine will start up automatically if the HV battery needs charging. Also, if MAX A/C is selected on a 2001 – 2003 Prius, the engine will run continuously due to the engine driven compressor. The 2004 & later Prius use an electric compressor.

Stopped

The engine may stop when the vehicle is not moving and the HV battery is fully charged.

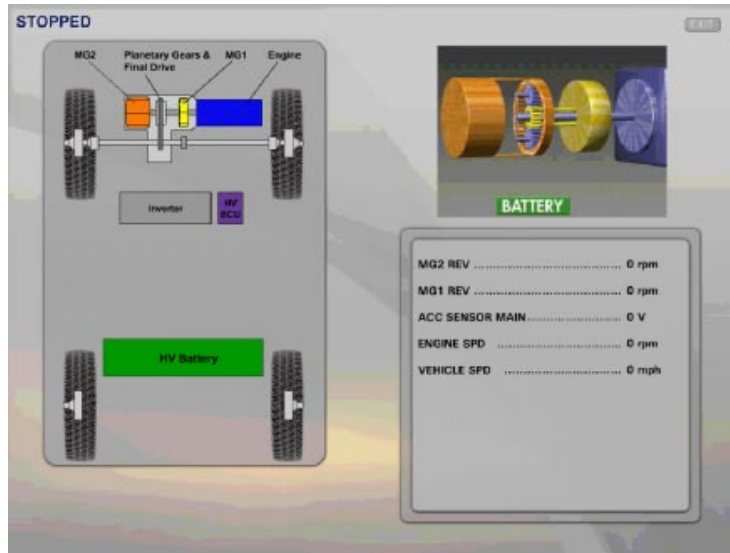

Figure 1.9

T071f109c

Starting Out When starting out under light load and light throttle, only MG2 turns to provide power. The engine does not run and the vehicle runs on electric power only. MG1 rotates backwards and just idles; it does not generate electricity.

Starting Out

The electric power supply from the HV battery to MG2 provides force to drive the wheels.

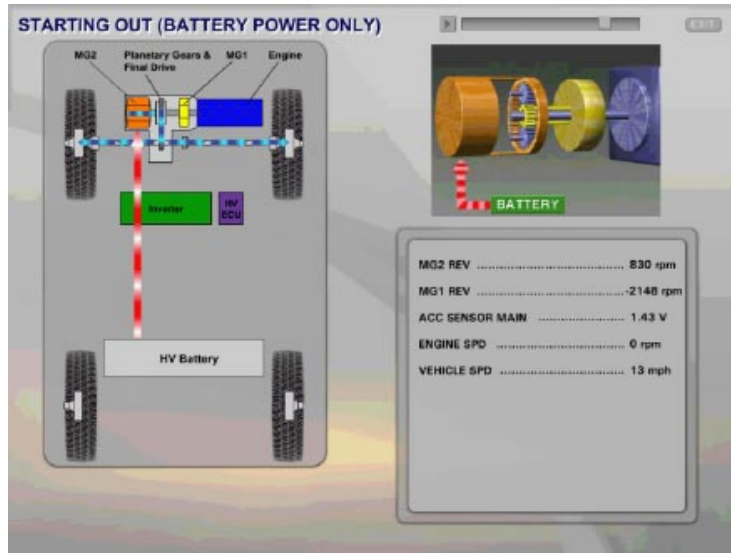

Figure 1.10

T072f103c

Normal Driving During normal low-speed driving (15 – 40mph), the engine runs and provides power. MG2 turns and runs as a motor and provides an electric assist. MG1 is turned in the same direction by the engine as a generator and provides electricity for MG2.

Normal Driving

While the engine drives the wheels via the planetary gears, MG1 is driven via the planetary gears to supply electricity to MG2.

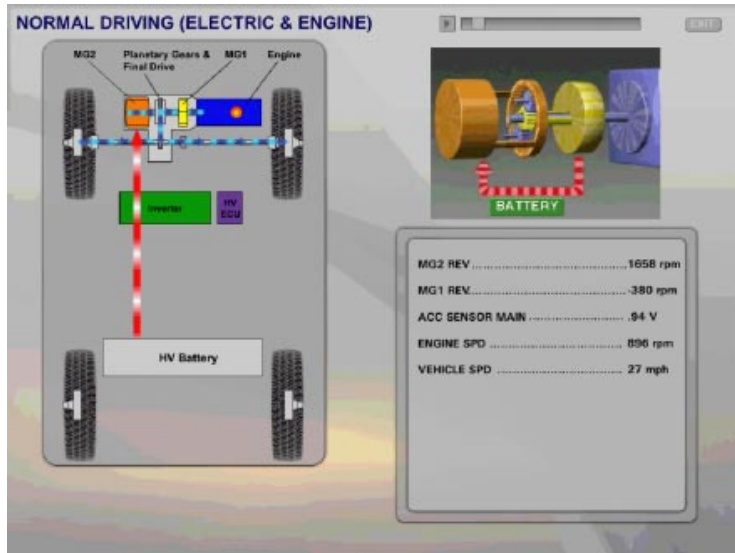

Figure 1.11

T072f104c

Full Throttle Acceleration and High Speed Cruise

For maximum acceleration or speed (over 100mph), electric drive power from MG2 supplements engine power. The HV battery provides electricity to MG2. MG1 also receives electrical power from the HV battery and turns in the reverse direction to create an overdrive ratio for maximum speed.

Full Throttle Acceleration and High Speed Cruise

MG2 supplements engine power for maximum acceleration or speed.

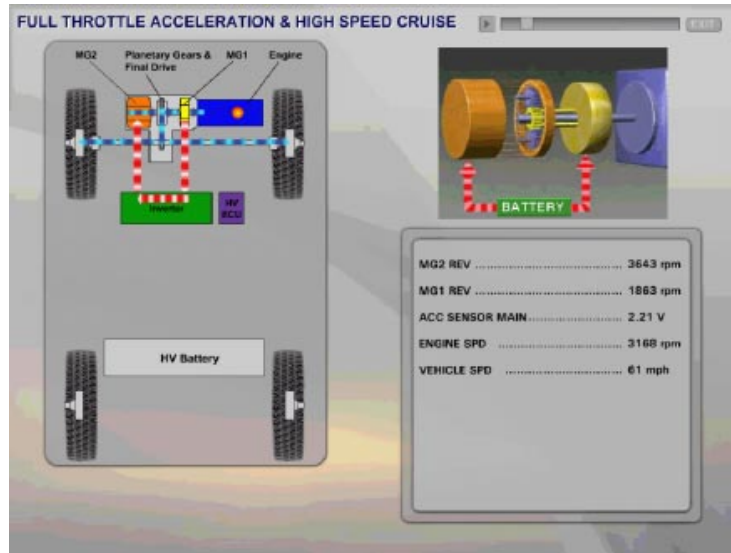

Figure 1.12

T072f105c

Deceleration and Braking As soon as the driver releases the accelerator pedal, MG2 becomes a generator. MG2 is turned by the drive wheels and generates electricity to recharge the HV battery. This process is called Regenerative Braking. As the vehicle decelerates, the engine stops running and MG1 turns backwards to maintain the gear ratio.

When the brake pedal is depressed, most initial braking force comes from Regenerative Braking and the force required to turn MG2 as a generator. The hydraulic brakes provide more stopping power as the vehicle slows.

Deceleration and Braking

When the vehicle decelerates, kinetic energy from the wheels is recovered and converted in to electrical energy and used to recharge the HV battery by means of MG2.

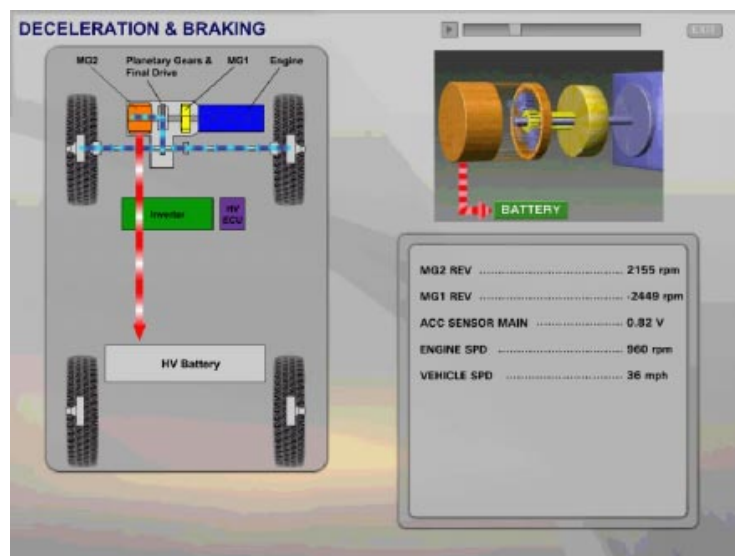

Figure 1.13

T072f106c

Reverse When the vehicle moves in reverse, MG2 turns in reverse as an electric motor. The engine does not run. MG1 turns in the forward direction and just idles; it does not generate electricity.

Reverse

MG2 rotates backwards to move the vehicle in reverse. The engine does not run.

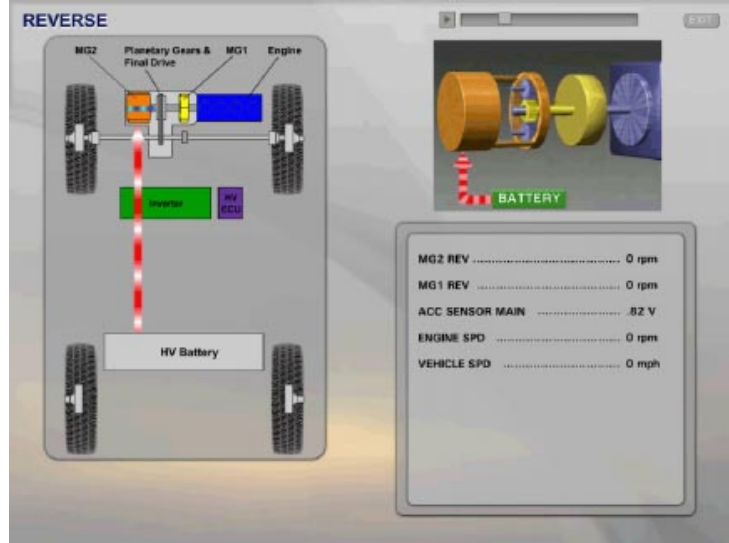

Figure 1.14

T072f107c

Multi Display A multi display is provided on the center cluster panel as standard equipment. The 7.0-inch LCD screen has a pressure sensitive panel for easy function accessibility.

Energy Monitor

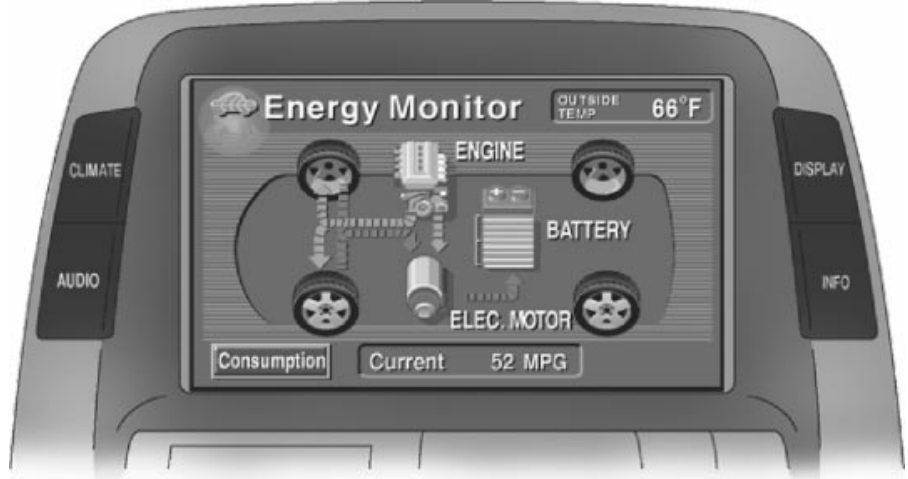

Figure 1.15

T071f115c

Fuel Consumption Screen

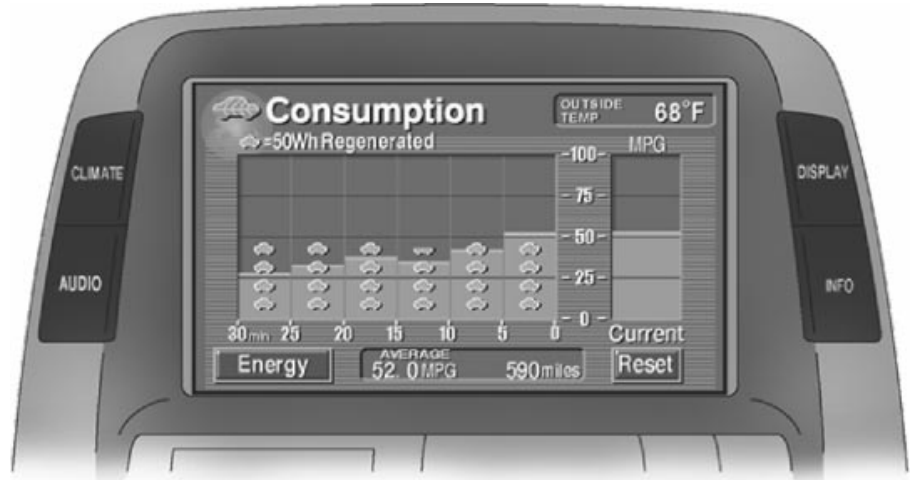

Figure 1.16

T071f116c

Smart Entry and Start System

In addition to the conventional mechanical key function and wireless door lock remote control function, this system provides a smart key with a bi-directional communication function. By enabling the smart ECU to recognize the presence of the smart key within the detection area, this system can lock or unlock the doors, or start the hybrid system without the use of the key, as long as the user has the smart key in their possession.

Door Open

Using smart entry by opening the door with smart key in pocket. The touch sensor is located on the back of the door handle.



Figure 1.17

T071f117c

Hybrid System Start

On the '01-'03 Prius, an ignition key is used to operate the key cylinder (containing the ignition switch), in order to switch the power mode of the vehicle and start the system.

On the '04 & later Prius, a push button start system operates the power switch by inserting a key in a key slot or by the driver keeping a key in their possession (models with smart entry and start system).

Power Mode

A power mode (OFF, ACC, IG-ON, or READY) can be selected by pressing the power switch. The indicator on this switch will tell you the power mode, which varies depending if the brake pedal is depressed or not while the switch is operated.

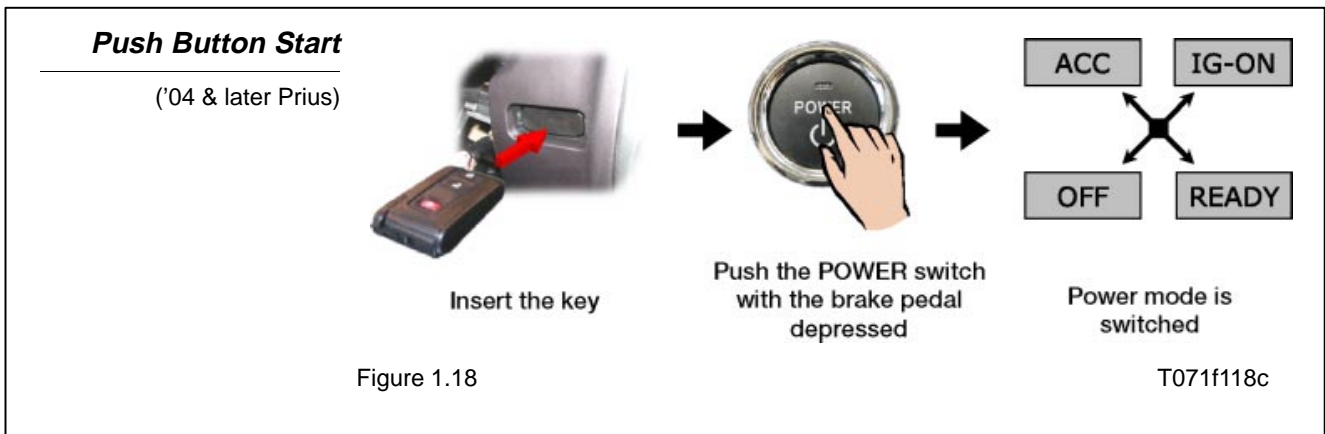

Hybrid System Start

Using smart start system by pressing the Power button with foot on brake and key in pocket.

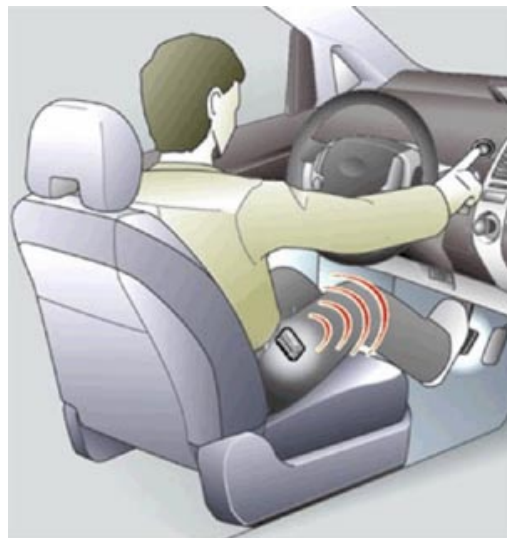

Figure 1.20

T071f120c

Smart Cancel Switch

('04 & later Prius)

To cancel smart key and smart on a '04 & later Prius. Simply press the smart cancel switch under the steering column.

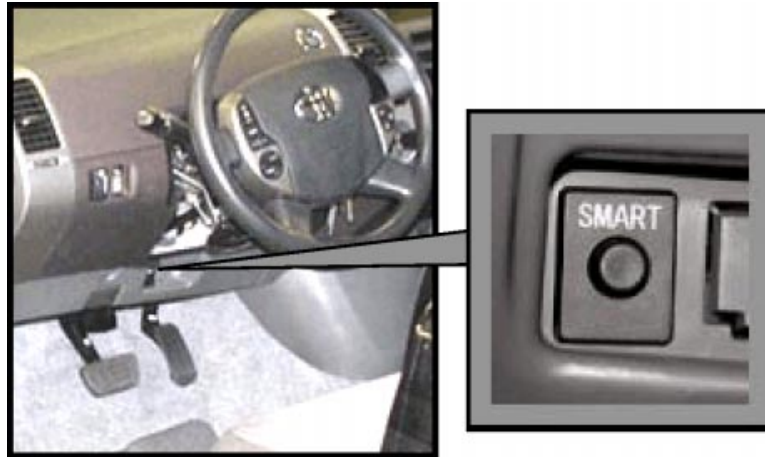

Figure 1.19

T071f119c

Power Mode – OFF or READY

Indicator light is OFF.

Indicator Light

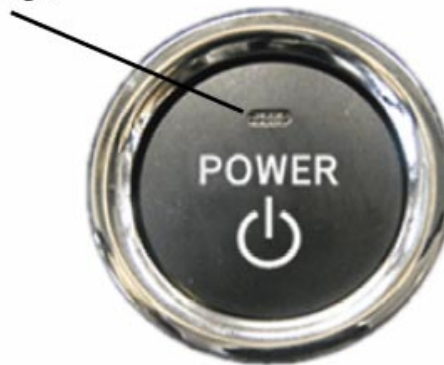

Figure 1.21

T071f121c

Power Mode - ACC

Indicator light is green.

Indicator Light



Figure 1.22

T071f122c

Power Mode - IG-ON

Indicator light is amber.

Indicator Light



Figure 1.23

T071f123c

Combination Meter

('04 & later Prius)



Figure 1.24

T071f124c



Notes



WORKSHEET 1-1
Hybrid System Overview

Vehicle	Year/Prod. Date	Engine	Transmission
---------	-----------------	--------	--------------

Worksheet Objectives

Review this sheet as you are doing the Hybrid System Overview worksheet. Check off either category after completing the worksheet and instructor presentation. Ask the instructor if you have questions. The **Comments** section is for you to write notes on where to find the information, questions, etc.

Tools and Equipment

- Vehicle
- Repair Manual
- New Car Features

Section 1: Hybrid Overview

1. On the multi display screen, view the fuel consumption screen. What different types of information are displayed on this screen?

2. Unlike a conventional vehicle, the Prius may or may not start the engine when the vehicle is turned ON. What alerts the driver that the vehicle is ready to drive?

3. What is the primary motive force when starting, backing up or under light loads?

Section 1

4. While driving, what do you think happens when you shift into the "B" position?

5. When the vehicle is decelerating or braking, what kind of energy from the wheels is recovered and converted into electrical energy to recharge the HV Battery?

6. Where is the 12V auxiliary battery located and what is its function? Can the 12V battery be jump-started?

7. How can you tell if the vehicle has smart key and smart start?

8. Does the vehicle you are working on have navigation? Does it have Bluetooth? How can you tell?

9. Where is the intake duct for the HV battery cooling system?

Section 2: Driving Characteristics

1. Make sure the parking brake is engaged. Will the vehicle start in neutral?

2. When the vehicle begins to move forward after the release of the parking brake and brake pedal, what power source is being used to move the vehicle?

3. On a 2004 and later Prius, how do you start the vehicle (READY light ON) with the Power button? With and without smart key?

4. What is unique about the steering system?

5. The engine may turn OFF periodically. List two conditions that will cause the engine to turn back ON.

Return all cars to the original state and return to the classroom.



Notes



SELF-ASSESSMENT 1-1
Hybrid System Overview

Name:	Date:
-------	-------

Self-assessment Objectives

Review this sheet as you are doing the Inclination Sensor Reset worksheet. Check off either category after completing the worksheet and instructor presentation. Ask the instructor if you have questions. The **Comments** section is for you to write notes on where to find the information, questions, etc.

I have questions

I know I can

Topic			Comment
Locate power button.			
Access the READY light.			
Use smart key & smart start.			
Locate the 12V battery.			
Locate the Navigation & Bluetooth functions.			



Notes

Section 2

Hybrid System Operation

Overview The Toyota hybrid system has two drive sources: the gasoline engine and the electric motor. The hybrid control system selects the best combination of those two power sources depending on driving conditions.

- The '01-'03 Prius uses THS (Toyota Hybrid System).
- The '04 & later Prius uses THS-II, which carries over the same basic concepts as the previous model but offers improvements to MG1 and MG2, the battery and engine.

Hybrid System Components

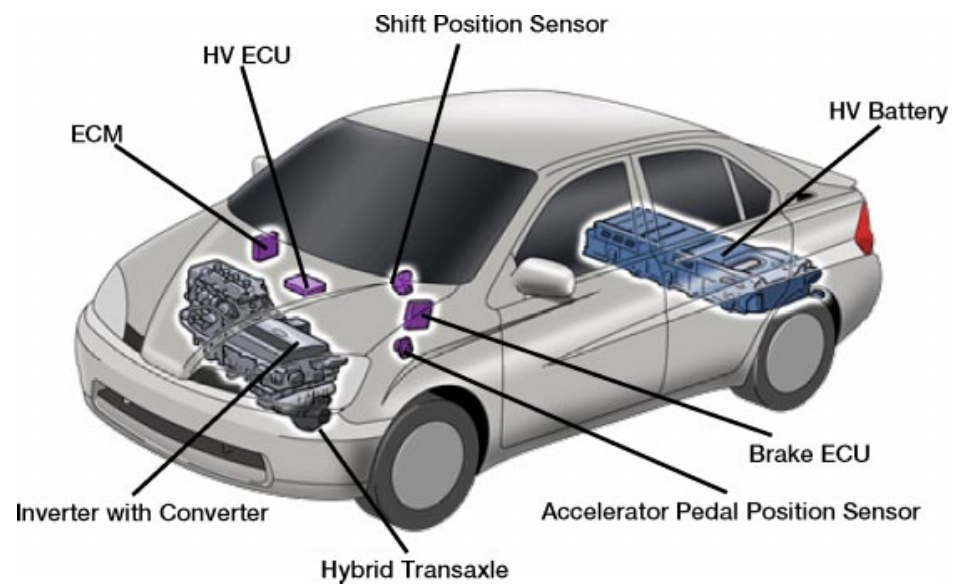
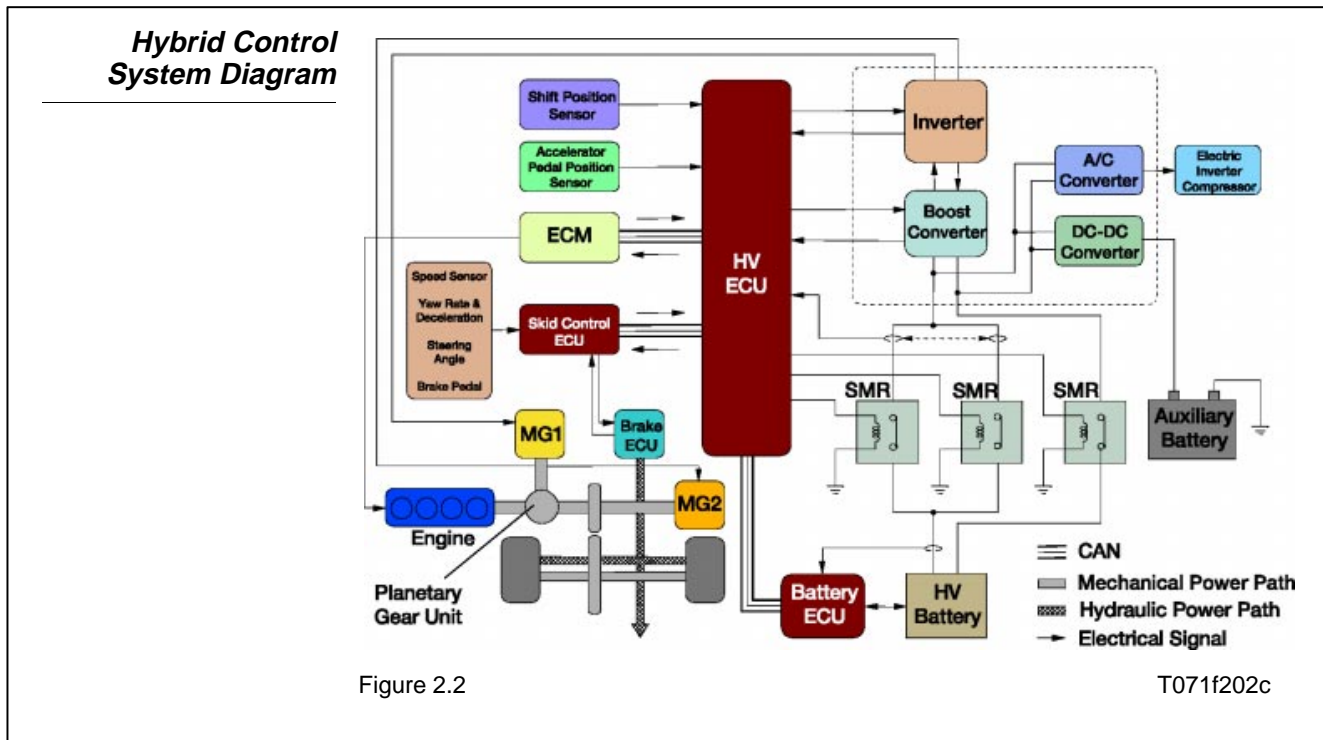

Figure 2.1

T072f002c



Hybrid System Components

Hybrid system components include:

- Hybrid Transaxle, consisting of MG1, MG2 and a Planetary Gear Unit
- 1NZ-FXE engine
- Inverter Assembly containing an inverter, a boost converter, a DC-DC converter, and an A/C inverter
- HV ECU, which gathers information from the sensors and sends calculated results to the ECM, inverter assembly, battery ECU and skid control ECU to control the hybrid system
- Shift Position Sensor
- Accelerator Pedal Position Sensor, which converts accelerator angle into an electrical signal
- Skid Control ECU that controls regenerative braking
- ECM
- HV Battery
- Battery ECU, which monitors the charging condition of the HV battery and controls cooling fan operation
- Service Plug, which shuts off the circuit
- The SMR (System Main Relay) that connects and disconnects the high-voltage power circuit
- Auxiliary Battery, which stores 12V DC for the vehicle's control systems

Safety Procedures Incorrectly performed hybrid system repairs could cause electrical shock, battery leakage or even an explosion. Be sure to perform the following safety procedures whenever servicing the hybrid vehicle's high-voltage system or hybrid control system:

- Remove the key from the ignition. If the vehicle is equipped with smart key, turn the smart key system off.
- Disconnect the negative (-) terminal of the auxiliary battery.
- Wear insulated gloves.
- Remove service plug and put it in your pocket.
- **Do not make any repairs for five minutes.**

If the key cannot be removed from the key slot (for instance, because of body damage during an accident) be sure to perform the following procedures:

- Disconnect the auxiliary battery.
- Remove the HEV fuse (20A yellow fuse in the engine compartment junction block.) When in doubt, pull all four fuses in the fuse block.

NOTE

High-voltage insulated gloves can be ordered from the Toyota SPX/OTC SST catalog under part numbers:

Small gloves – 00002-03100-S

Medium gloves – 00002-03200-M

Large gloves – 00002-03300-L

To check the integrity of the glove's surface, blow air into the glove and fold the base of the glove over to seal the air inside. Then, slowly roll the base of the glove towards the fingers.

- If the glove holds pressure, its insulating properties are intact.
- If there is an air leak, high-voltage electricity can find its way back through that same hole and into your body! Discard the glove(s) and start over until you have a pair of gloves that can fully protect you from the vehicle's high-voltage circuits.

WARNING

After disabling the vehicle, power is maintained for 90 seconds in the SRS system and for five minutes in the high-voltage electrical system. If any of the disabling steps above cannot be performed, proceed with caution as there is no assurance that the high-voltage electrical system, SRS or fuel pumps are disabled. Never cut orange high-voltage power cables or open high-voltage components.

WARNING

Due to circuit resistance, it takes at least five minutes before high-voltage is discharged from the inverter circuit. Even after five minutes have passed, the following safety precautions should be observed:

- Before touching an orange high-voltage cable, or any other cable that you cannot identify, use the tester to confirm that the voltage in the cable is 12V or less.
- After removing the service plug, cover the plug connector using rubber or vinyl tape.
- After removing a high-voltage cable, be sure to cover the terminal using rubber or vinyl tape.
- Use insulated tools when available.
- Do not leave tools or parts (bolts, nuts, etc.) inside the cabin.
- Do not wear metallic objects. (A metallic object may cause a short-circuit.)

Submerged Vehicle Safety

Many fire departments and police stations have been trained to safely remove hybrid vehicles from water in case of an emergency. Always call your local fire department in this situation.

To safely handle a Prius that is fully or partially submerged in water, disable the high-voltage electrical system and SRS airbags. Remove the vehicle from the water. Drain the water from the vehicle if possible. Then, follow the extrication and vehicle disable procedures below:

- Immobilize the vehicle.
- Chock the wheels and set the parking brake.
- Remove the key from the key slot.
- If equipped with smart key, use the smart cancel switch underneath the steering column to disable the system.
- Keep the electronic key at least 16 feet (5 meters) away from the vehicle.
- Disconnect the 12V auxiliary battery.
- Remove the HEV fuse in the engine compartment. When in doubt, pull all four fuses in the fuse block.

Service Plug

('01-'03 Prius)

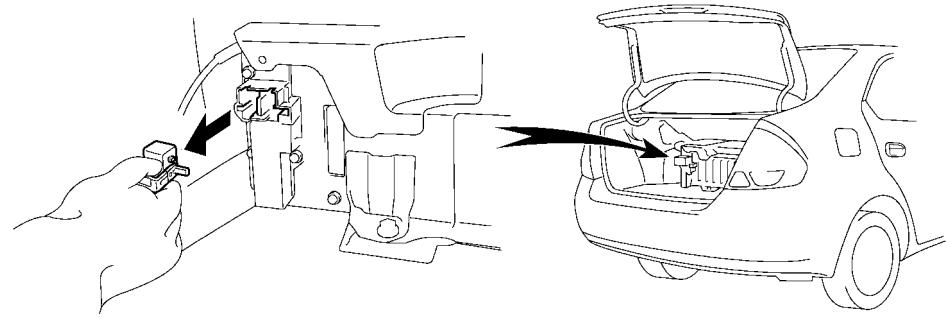

Figure 2.3

T071f203c

Service Plug

('04 & later Prius)

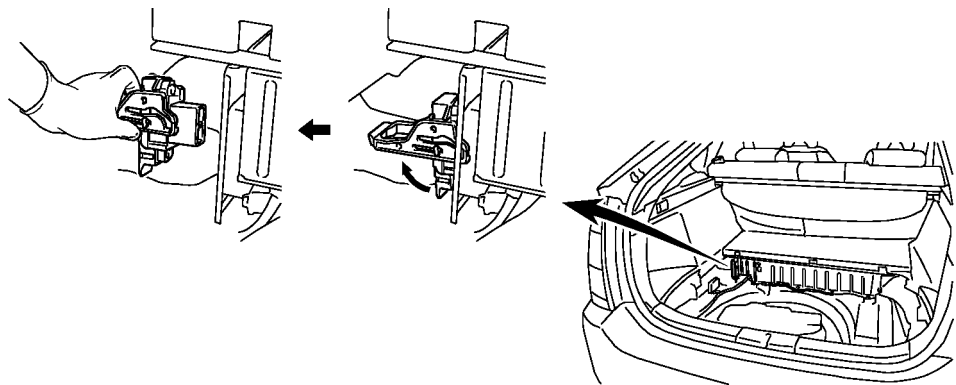

Figure 2.4

T071f204c

Hybrid Transaxle The hybrid transaxle contains:

- Motor Generator 1 (MG1) that generates electrical power.
- Motor Generator 2 (MG2) that drives the vehicle.
- A planetary gear unit that provides continuously variable gear ratios and serves as a power splitting device.
- A reduction unit consisting of a silent chain, counter gears and final gears.
- A standard 2-pinion differential

The '01-'03 Prius uses the P111 hybrid transaxle.

The '04 & later Prius uses the P112 hybrid transaxle. The P112 is based on the P111, but offers a higher RPM range, V-shaped permanent magnets in the rotor of MG2, and a newly designed over-modulation control system.

Hybrid Transaxle

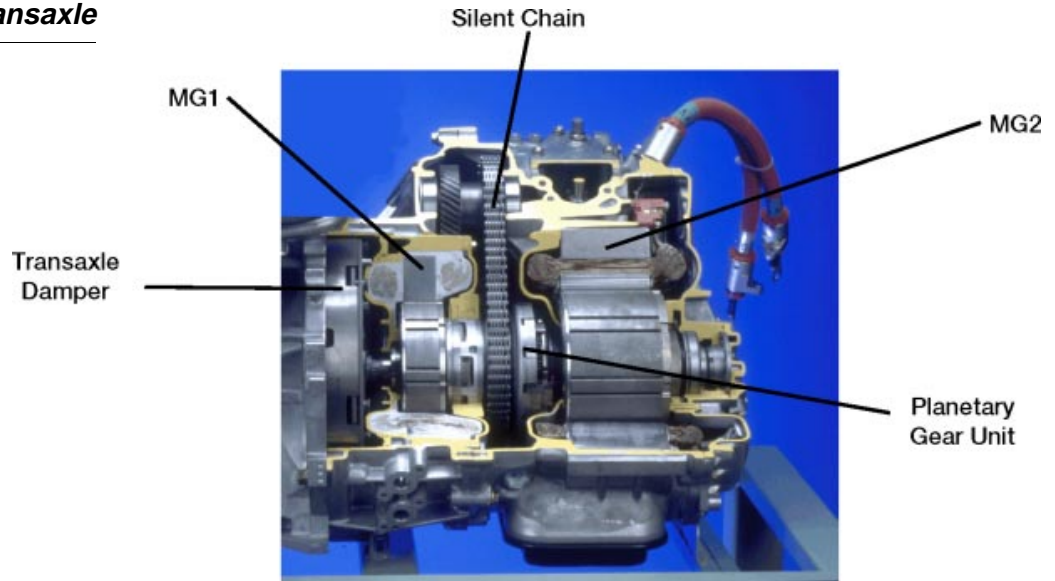

Figure 2.5

T071f205p

Transaxle Damper The transaxle damper uses a spring coil with low torsional characteristics. In the '04 & later Prius, the spring rate characteristics of the coil spring have been reduced further to improve its vibration absorption performance and the shape of the flywheel has been optimized for weight reduction.

Transaxle Damper

The transaxle damper, which transmits the drive force of the engine to the transaxle, contains a torque fluctuation adsorption mechanism that uses a dry, single plate friction material.



Figure 2.6

T071f206p

Hybrid Transaxle Specifications		'04 Model	'03 Model
		Transaxle Type	P112
Planetary Gear	The No. of Ring Gear Teeth	78	←
	The No. of Pinion Gear Teeth	23	←
	The No. of Sun Gear Teeth	30	←
Differential Gear Ratio		4.113	3.905
Chain	Number of Links	72	74
	Drive Sprocket	36	39
	Driven Sprocket	35	36
Counter Gear	Drive Gear	30	←
	Driven Gear	44	←
Final Gear	Drive Gear	26	←
	Driven Gear	75	←
Fluid Capacity	Liters (US qts, Imp qts)	3.8 (4.0, 3.3)	4.6 (4.9, 4.0)
Fluid Type		ATF WS or equivalent	ATF Type T-IV or equivalent

MG1 & MG2 Motor Generator 1 & Motor Generator 2 MG1 and MG2 function as both highly efficient alternating current synchronous generators and electric motors. MG1 and MG2 also serve as sources of supplemental motive force that provide power assistance to the engine as needed.

MG1 Specifications		'04 Model	'03 Model
Item			
Type		Permanent Magnet Motor	
Function		Generate, Engine Starter	
Maximum Voltage	[V]	AC 500	AC 273.6
Cooling System		Water-cooled	
MG2 Specifications		'04 Model	'03 Model
Item			
Type		Permanent Magnet Motor	
Function		Generate, Engine Starter	
Maximum Voltage	[V]	AC 500	AC 273.6
Maximum Output	kW (PS) / rpm	50 (68) / 1,200 ~ 1,540	33 (45) / 1,040 ~ 5,600
Maximum Torque	N•m (kgf•m) / rpm	400 (40.8) / 0 ~ 1,200	350 (35.7) / 0 ~ 400
Cooling System		Water-cooled	

Figure 2.7

T071f207c

MG1 Description MG1 recharges the HV battery and supplies electrical power to drive MG2. In addition, by regulating the amount of electrical power generated (thus varying MG1’s internal resistance and rpm), MG1 effectively controls the transaxle’s continuously variable transmission. MG1 also serves as the engine starter.

MG2 Description MG2 and the engine work together to drive the wheels. The addition of MG2’s strong torque characteristics help achieve excellent dynamic performance, including smooth start-off and acceleration. During regenerative braking, MG2 converts kinetic energy into electrical energy, which is then stored in the HV battery.

NOTE Towing a damaged Prius with its front wheels on the ground may cause MG2 to generate electricity. If that happens, the electrical insulation could leak and cause a fire. Always tow the vehicle with the front wheels off of the ground or on a flat bed.

Planetary Gear Unit The planetary gear unit is used as a power splitting device. The sun gear is connected to MG1, the ring gear is connected to MG2, and the planetary carrier is connected to the engine output shaft. The motive force is transmitted from the chain drive sprocket to the reduction unit via a silent chain.

Planetary Gear Connection

Item	Connection
Sun Gear	MG1
Ring Gear	MG2
Carrier	Engine Output Shaft

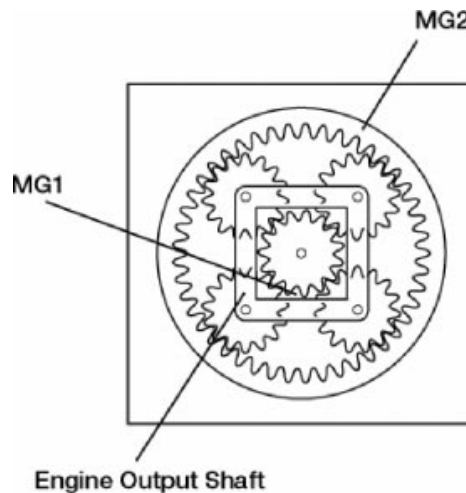

Figure 2.8

T072f035

Reduction Unit The reduction unit consists of the silent chain, counter gears and final gears. A silent chain with a small pitch width ensures quiet operation. The overall length has been reduced in contrast to the gear-driven mechanism. The counter gear and final gear teeth have been processed through high-precision honing and their tooth flanks have been optimized to ensure extremely quiet operation.

Reduction Unit

The final gears have been optimized to reduce the distance between the engine's center shaft and the differential shaft, resulting in a more compact transmission.

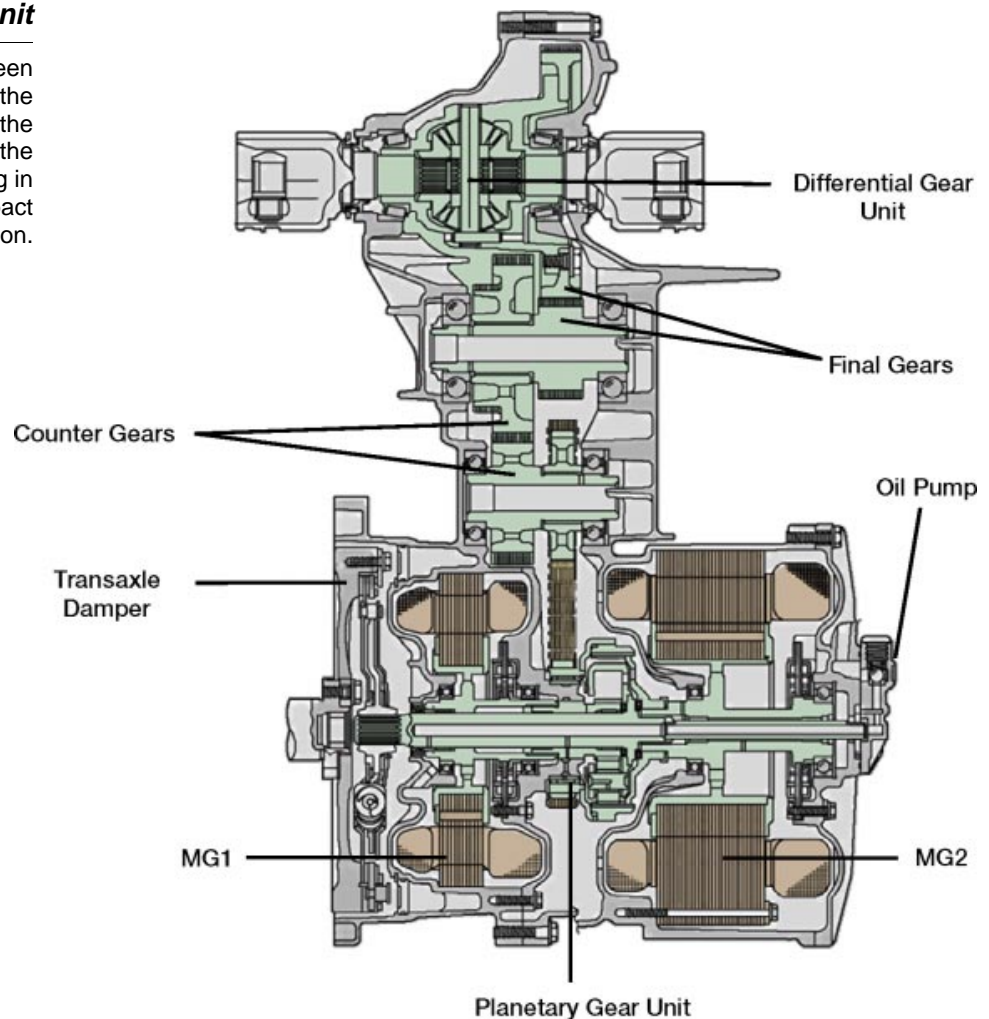

Figure 2.9

T071f209c

Permanent Magnet Motor

When three-phase alternating current is passed through the windings of the stator coil, a rotating magnetic field is created. When the rotation of this magnetic field is properly timed in relationship to the rotor, the magnetic field pulls the permanent magnets housed inside the rotor in a circle, causing the rotor to turn and creating the motor's torque. The generated torque is proportionate to the amount of current passing through the stator coils and the rotational speed is controlled by the frequency of the three-phase alternating current.

A high level of torque can be generated efficiently at all speeds by properly controlling the rotating magnetic field and the angles of the rotor magnets.

On the '04 & later Prius the built-in permanent magnets have been changed to a V-shaped structure to improve both power output and torque.

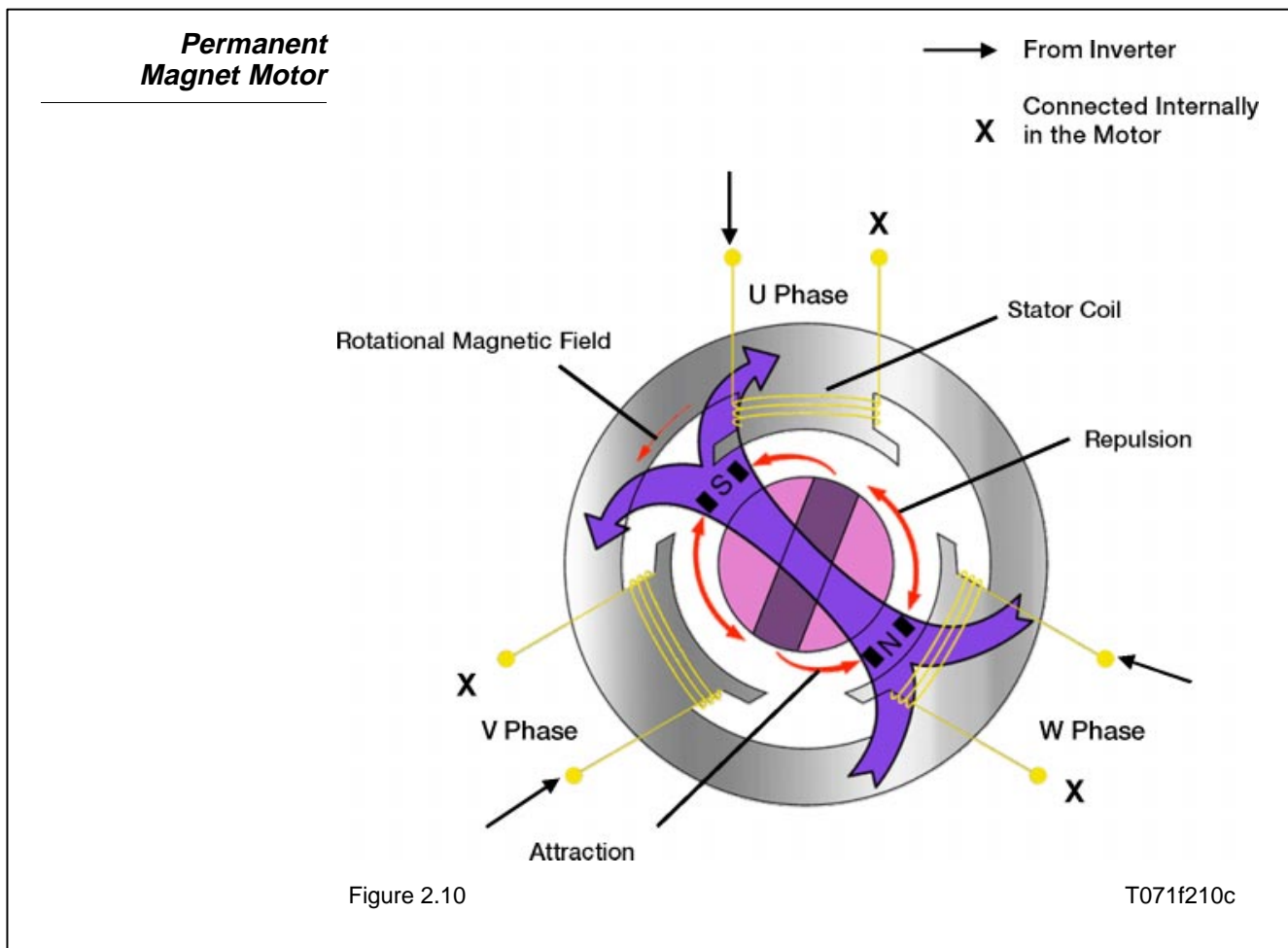

Permanent Magnet Structure

The V-shaped structure of the magnets in the '04 & later model provides about 50% more power than previous models.

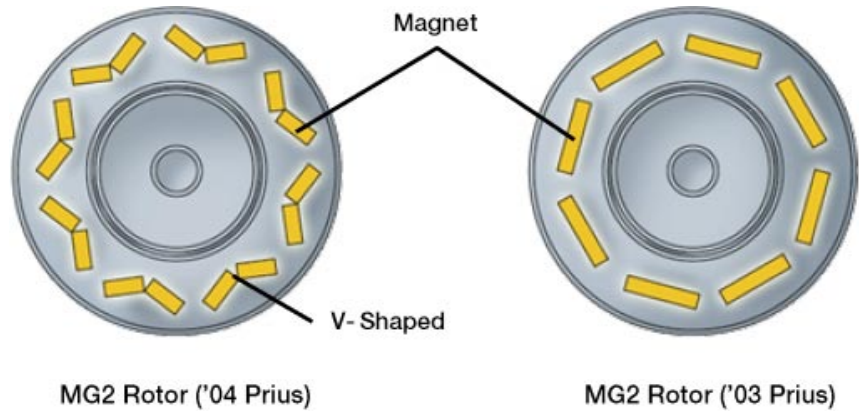

Figure 2.11

T071f211c

Speed Sensor (Resolver)

This reliable and compact sensor precisely detects the magnetic pole position, which is essential for the control of MG1 and MG2.

The sensor's stator contains three coils. Since the rotor is oval, the gap between the stator and the rotor varies with the rotation of the rotor.

In addition, the HV ECU uses this sensor as an rpm sensor, calculating the amount of positional variance within a predetermined time interval.

Speed Sensor (Resolver) Operation

Output coils B and C are electrically staggered 90 degrees. Because the rotor is oval, the distance of the gap between the stator and the rotor varies with the rotation of the rotor. By passing an alternating current through coil A, output that corresponds to the sensor rotor's position is generated by coils B and C. The absolute position can then be detected from the difference between these outputs.

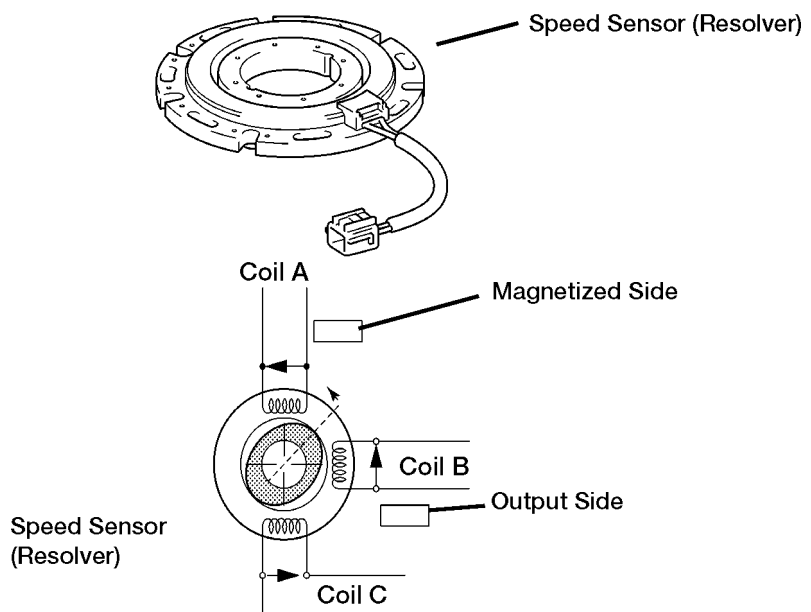

Figure 2.12

T071f212

Inverter Assembly

('04 & later Prius)



Figure 2.13

T071f213p

Inverter The inverter changes high-voltage direct current from the HV battery into three-phase alternating current for MG1 and MG2. The HV ECU controls the activation of the power transistors. In addition, the inverter transmits information that is needed to control current, such as the output amperage or voltage, to the HV ECU.

The inverter, MG1, and MG2, are cooled by a dedicated radiator and coolant system that is separate from the engine coolant system. The HV ECU controls the electric water pump for this system. In the '04 & later Prius, the radiator has been simplified and the space it occupies has been optimized.

Boost Converter ('04 & later Prius) The boost converter boosts the nominal voltage of 201.6V DC that is output by the HV battery to the maximum voltage of 500V DC. To boost the voltage, the converter uses a boost IPM (Integrated Power Module) with a built-in IGBT (Insulated Gate Bipolar Transistor) for switching control, and a reactor to store the energy.

When MG1 or MG2 acts as a generator, the inverter converts the alternating current (range of 201.6V to 500V) generated by either motor into direct current, then the boost converter drops the voltage to 201.6V DC to charge the HV battery.

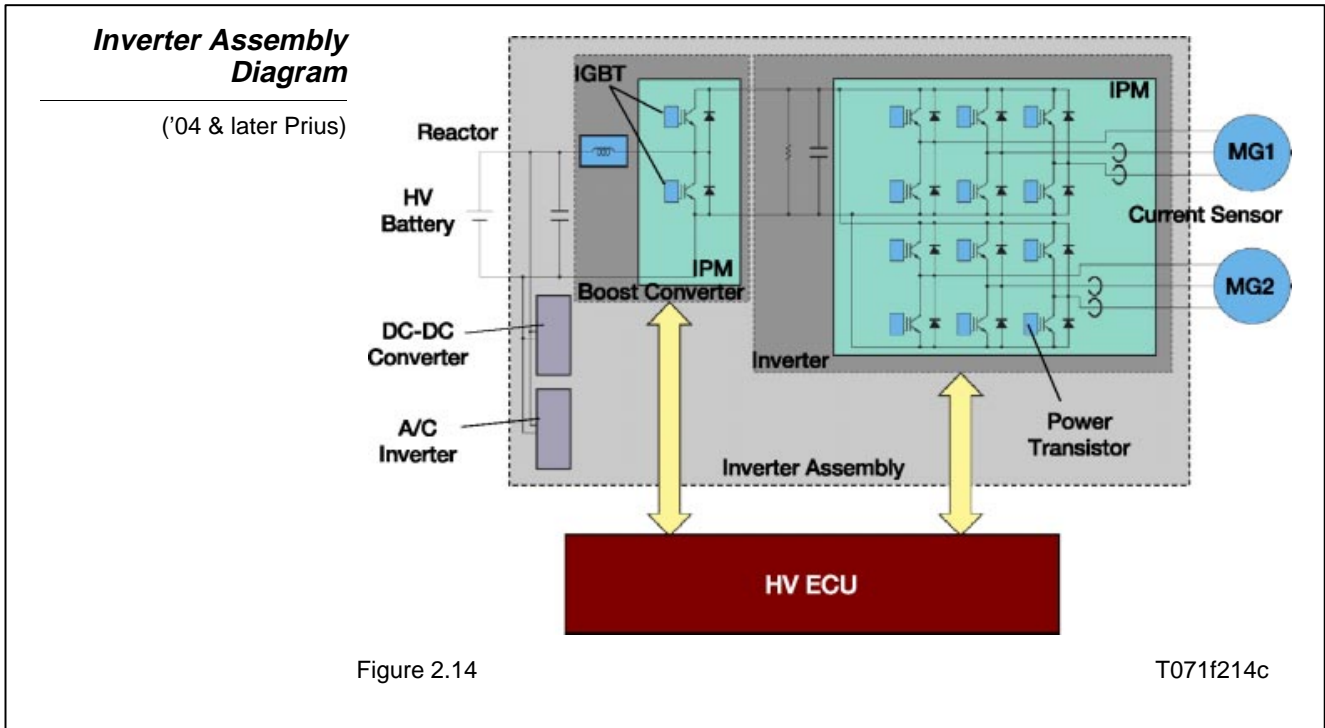

Converter The vehicle's auxiliary equipment (such as lights, audio system, A/C cooling fan, ECUs, etc.) is powered by standard 12V DC.

On the '01-'03 Prius, the THS generator voltage is 273.6V DC. A converter transforms the voltage from 273.6V DC to 12V DC to recharge the auxiliary battery.

On the '04 and later Prius, the THS-II generator outputs a nominal voltage of 201.6V DC. The converter transforms the voltage from 201.6V DC to 12V DC to recharge the auxiliary battery.

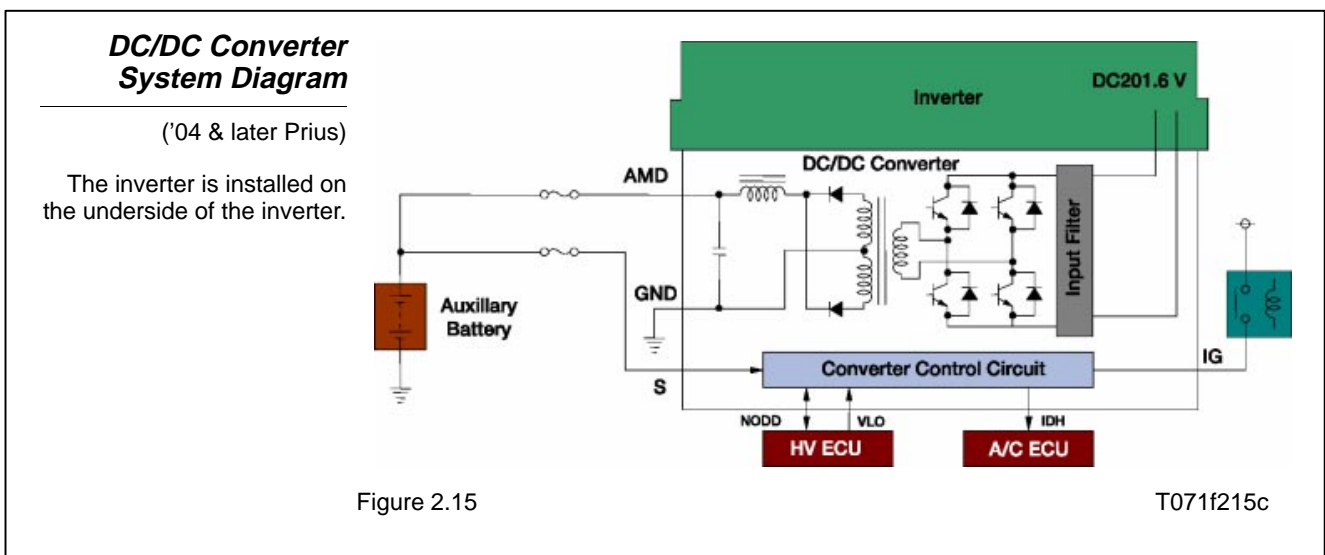

A/C Inverter ('04 & later Prius) The inverter assembly includes a separate inverter for the air conditioning system that changes the HV battery's nominal voltage of 201.6V DC into 201.6V AC to power the air conditioning system's electric inverter compressor.

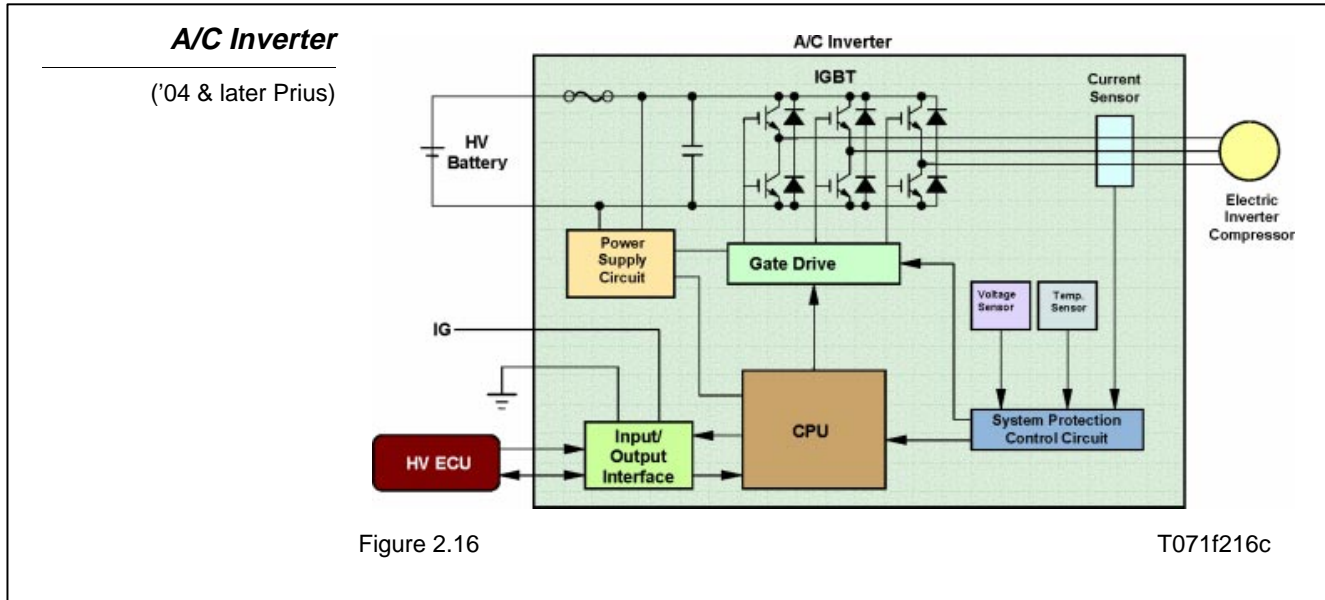

Cooling System for Inverter, MG1 and MG2

A dedicated cooling system uses a water pump to cool the inverter, MG1 and MG2. It is separate from the engine cooling system. This cooling system activates when the power supply is switched to IG.

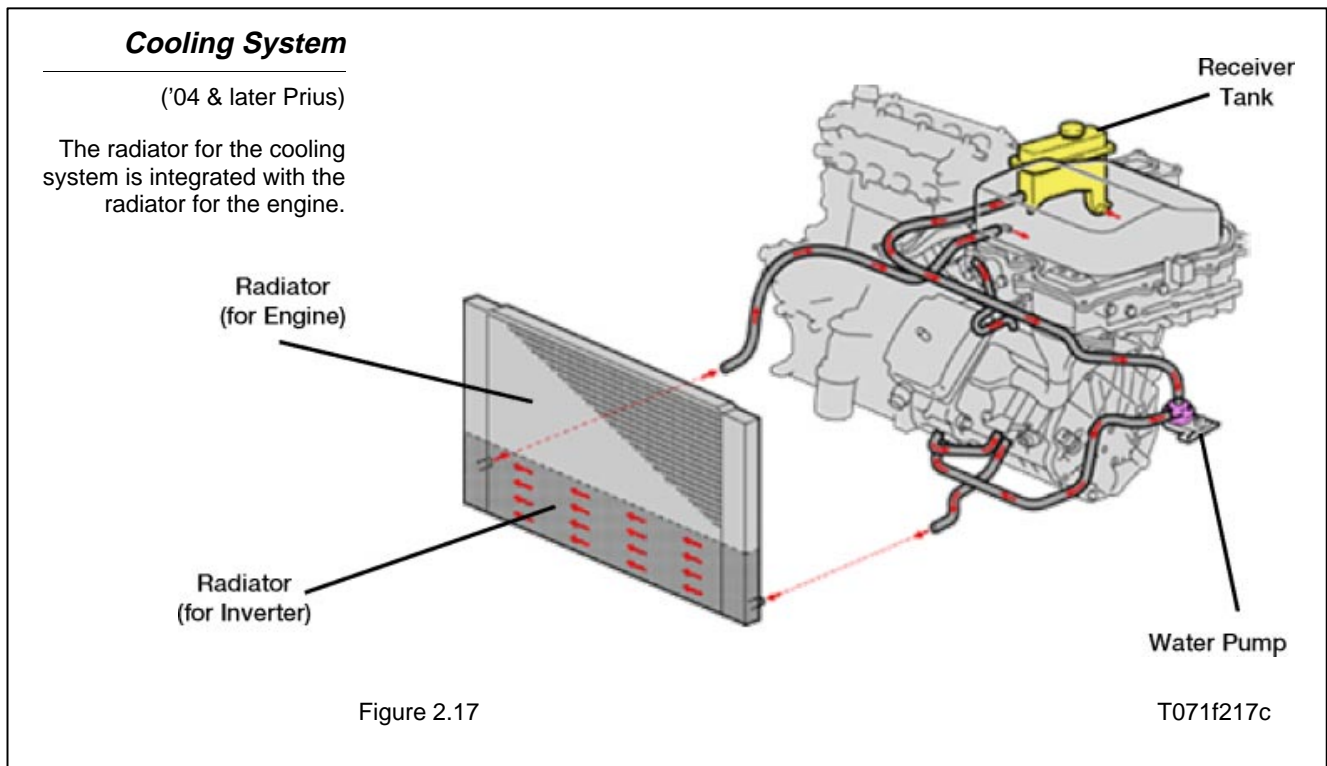

HV ECU The HV ECU:

- Controls MG1, MG2 and the engine based on torque demand, regenerative brake control and the HV Battery’s State of Charge (SOC). These factors are determined by the shift position, the degree with which the accelerator is depressed and vehicle speed.
- The HV ECU monitors HV Battery SOC and the temperature of the HV battery, MG1 and MG2.
- To ensure reliable circuit shutdown and protect the vehicle’s circuits from high-voltage, the HV ECU uses three relays housed in the System Main Relay assembly to connect and disconnect the high-voltage circuit.
- If the HV ECU detects a malfunction in the hybrid system, it will control the system based on the data that is stored in its memory.

Nomographs A nomograph is a kind of chart that conveys the relationship between different sets of numbers. The hybrid operation nomographs below convey the relationship between RPM for MG1, MG2 and the engine.

Because MG1, MG2 and the engine are mechanically connected in the Planetary Gear Set, if one of the components changes rpm, the rpm of the other components will be affected. So in the nomograph, the rpm values of the 3 power sources maintain a relationship in which they are always connected by a straight line.

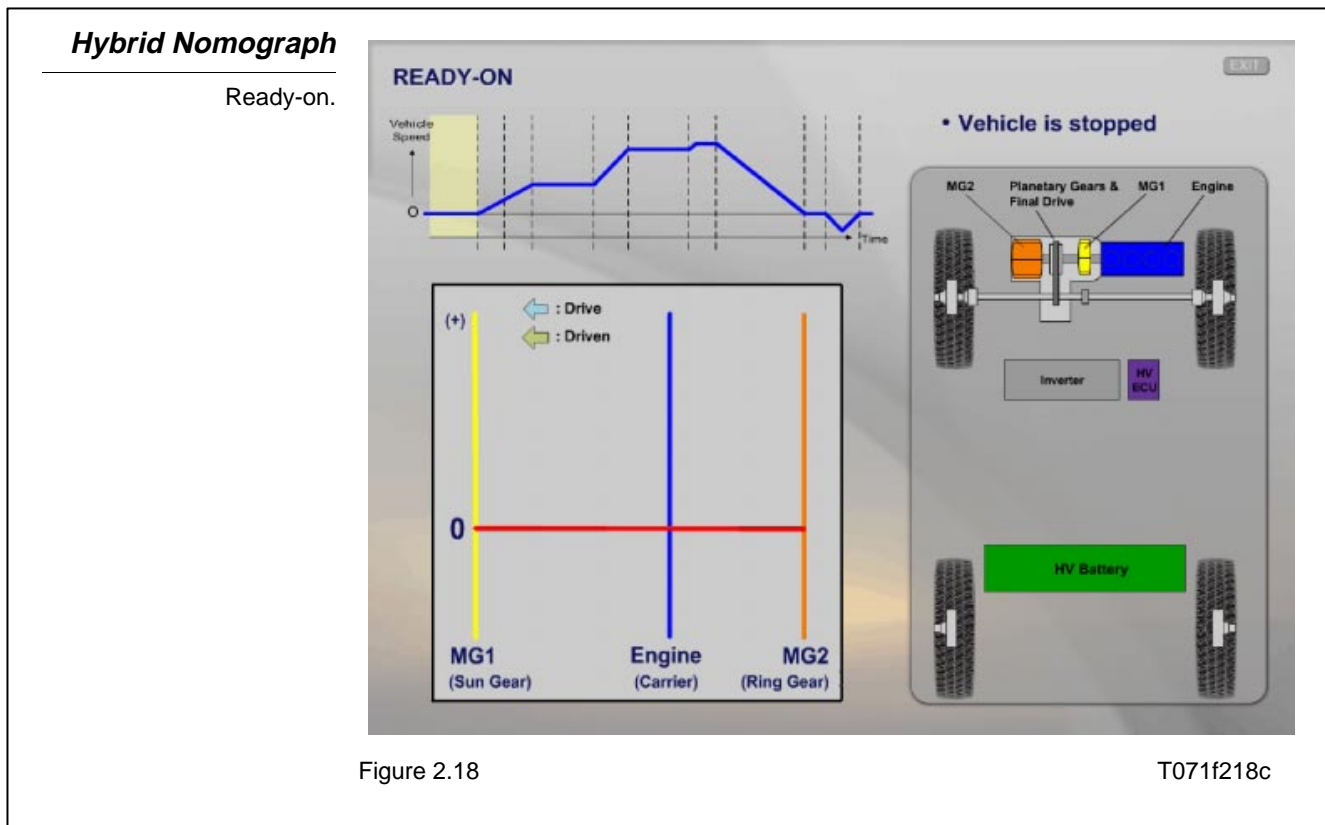

Hybrid Nomograph

Starting out.

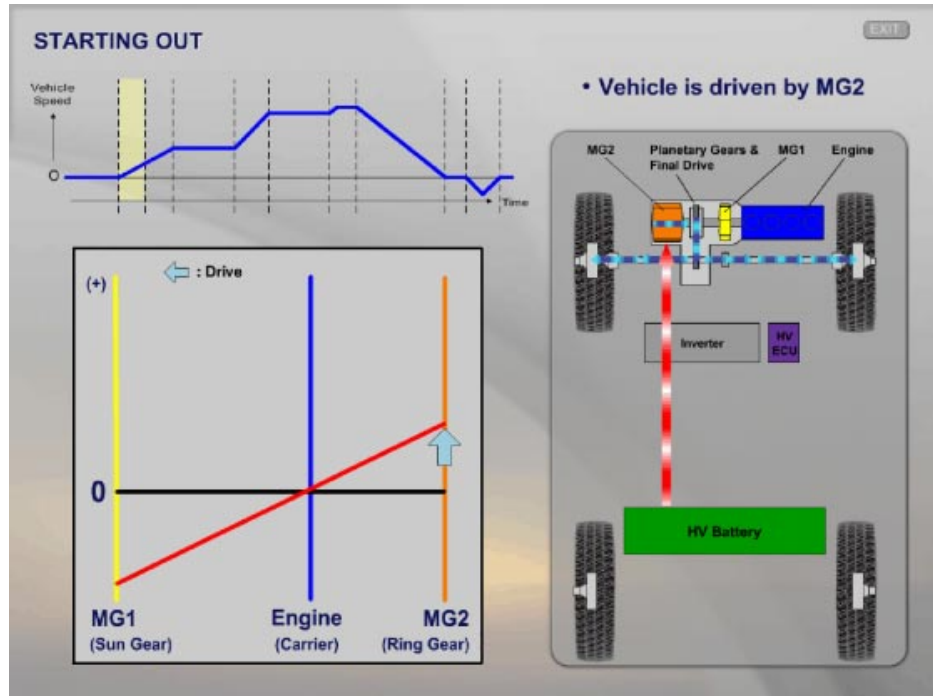

Figure 2.19

T071f219c

Hybrid Nomograph

Engine starting.

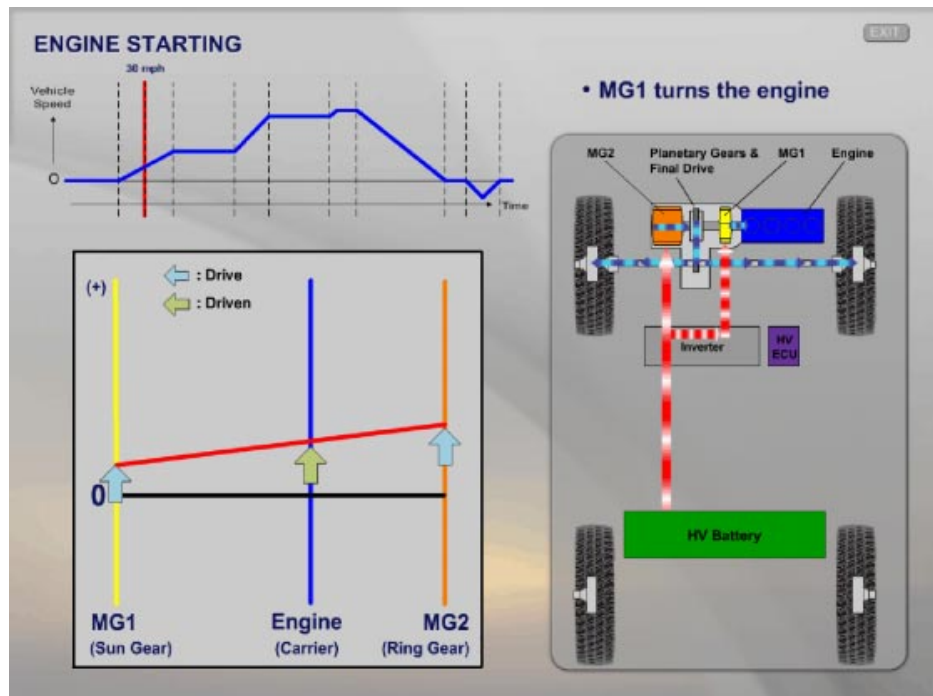

Figure 2.20

T071f220c

Hybrid Nomograph

Light acceleration with engine.

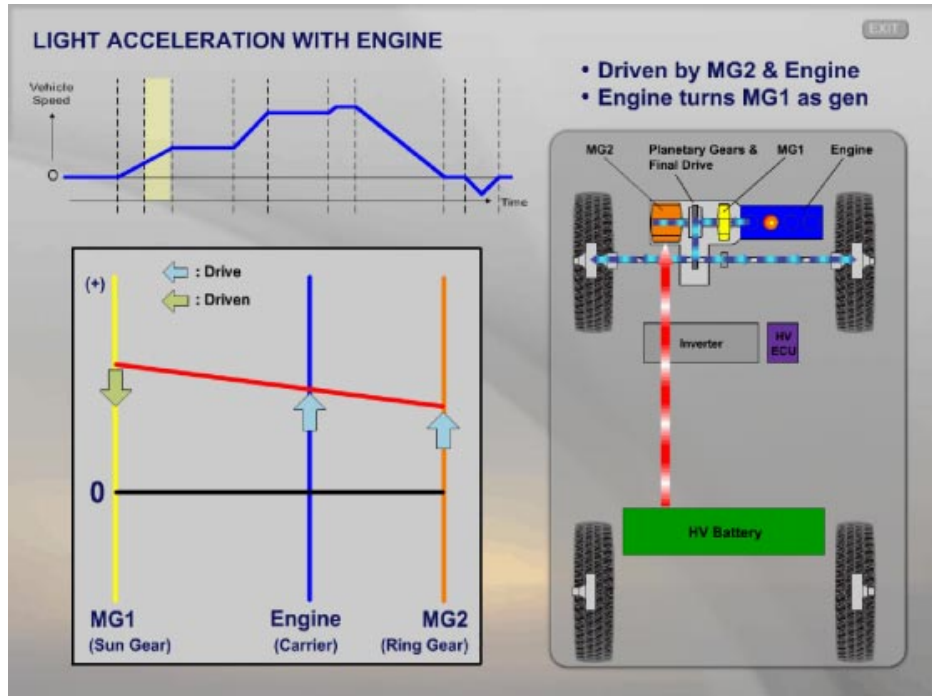

Figure 2.21

T071f221c

Hybrid Nomograph

Low speed cruising.

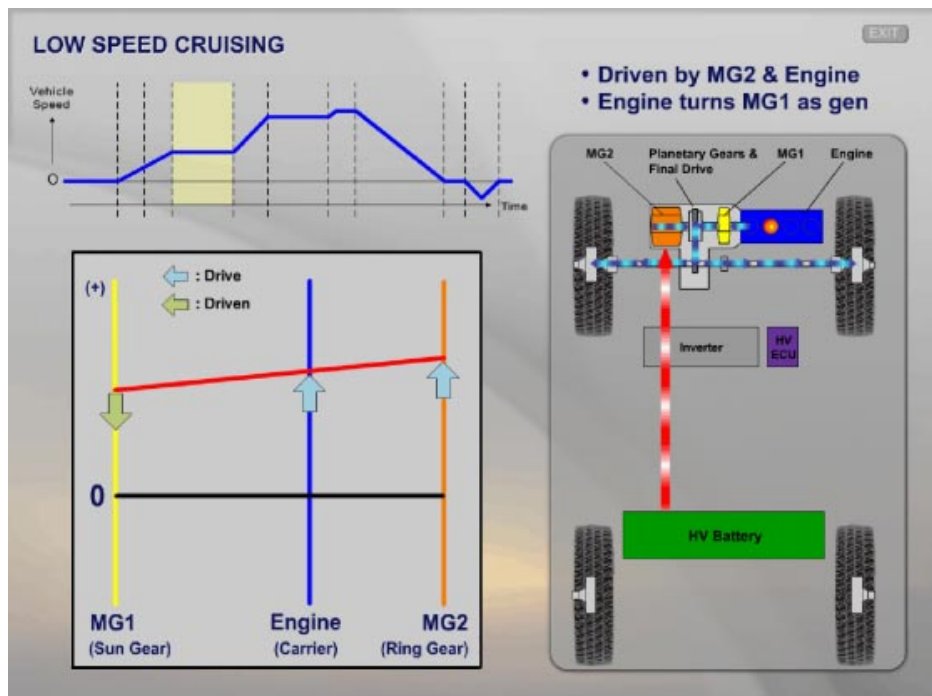

Figure 2.22

T071f222c

Hybrid Nomograph

Full acceleration.

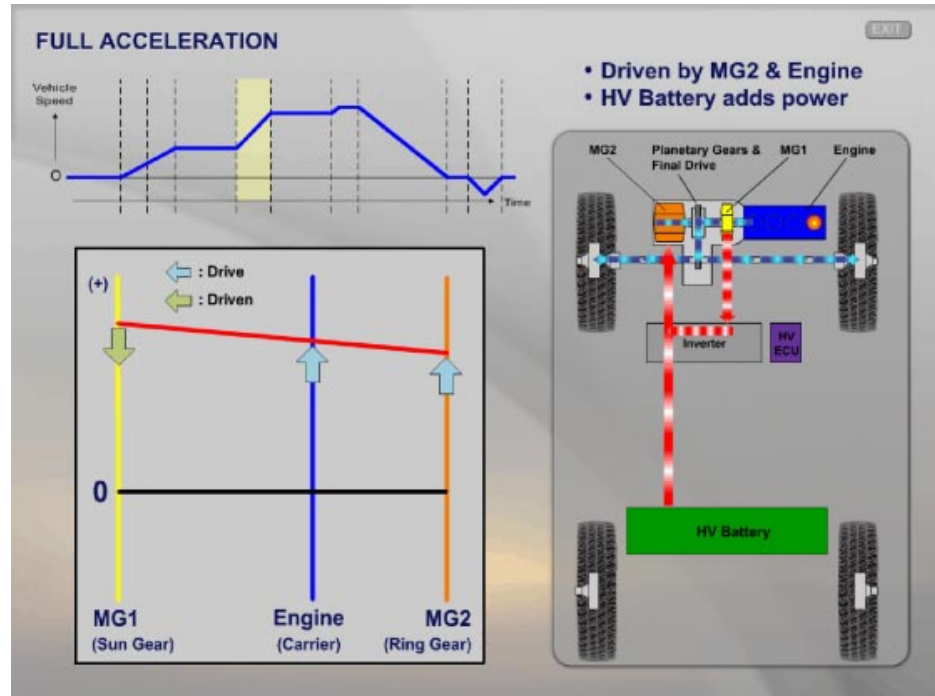

Figure 2.23

T071f223c

Hybrid Nomograph

High speed cruising.

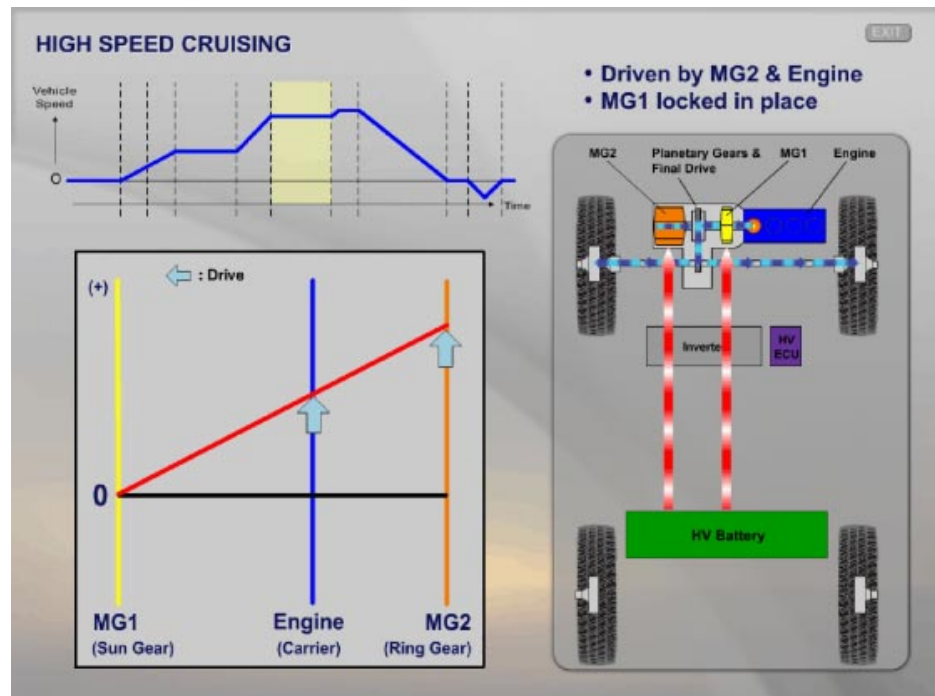

Figure 2.24

T071f224c

Hybrid Nomograph

Max speed.

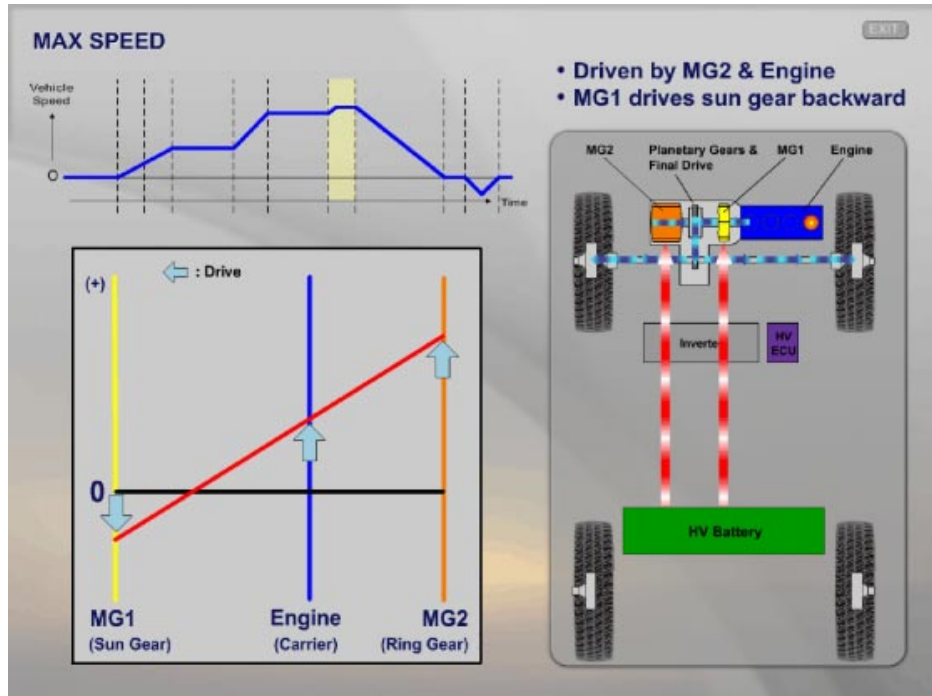

Figure 2.25

T071f225c

Hybrid Nomograph

Deceleration or braking.

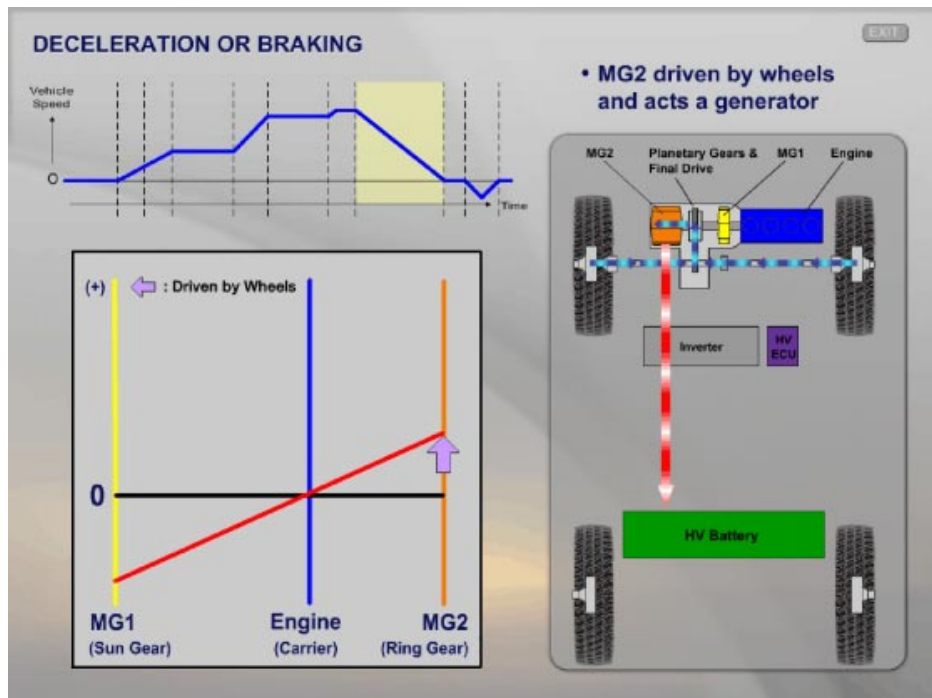

Figure 2.26

T071f226c

Hybrid Nomograph

Reverse.

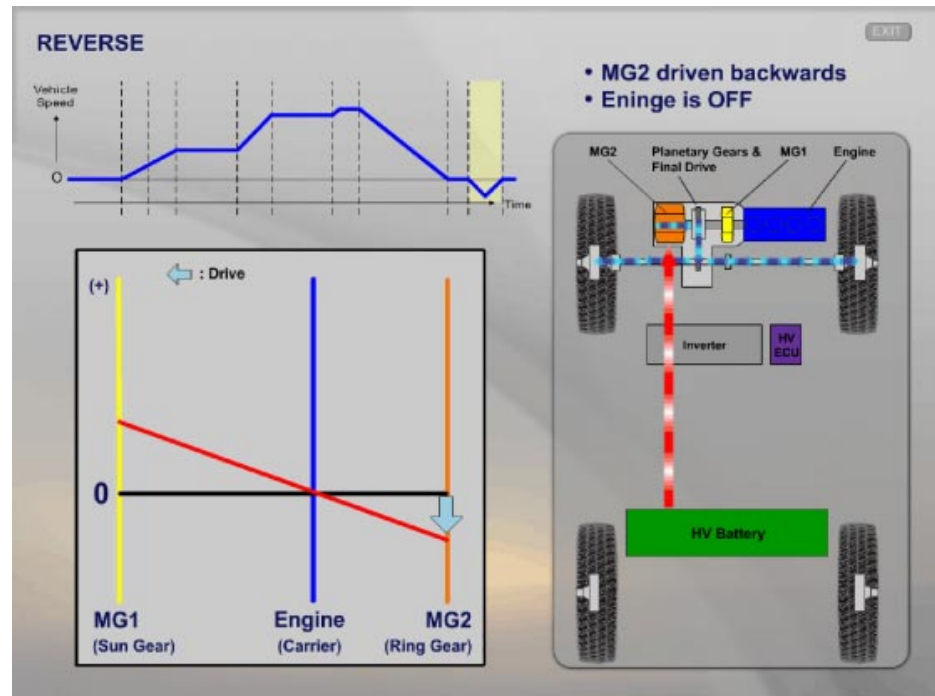

Figure 2.27

T071f227c

Using Information Codes

Information Codes are a three-digit supplement to HV ECU DTCs. They provide additional information and freeze frame data to help diagnose the vehicle's condition. These codes can be found on the Diagnostic Tester **HV ECU** menu. Use the screen flow shown below to access the codes. For a detailed description of each Information Code, refer to the DI section of the Repair Manual.

Accessing Information Codes

Follow the screen flow to access the Information Codes.

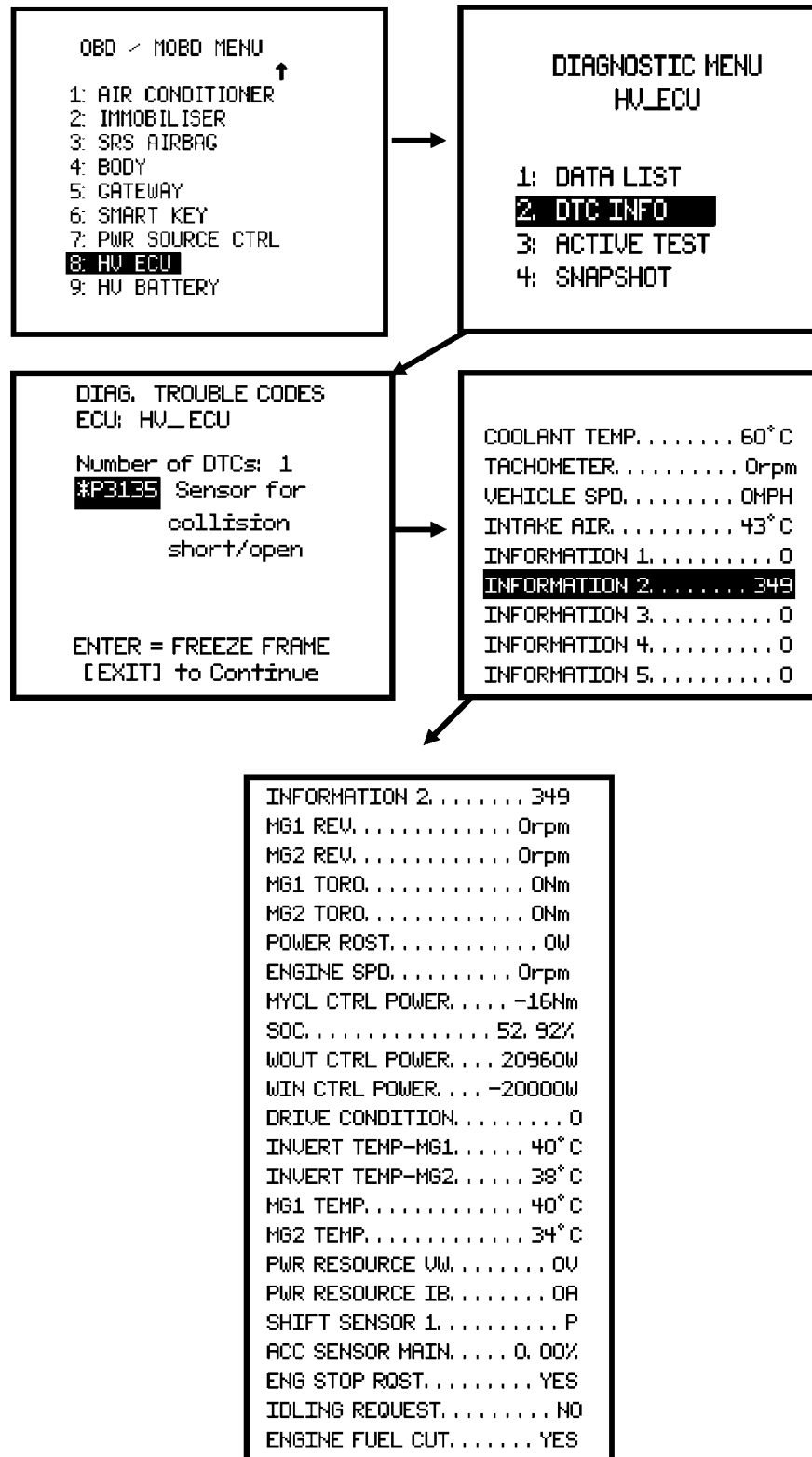

Figure 2.28

T071f228



WORKSHEET 2-1
Hybrid Safety

Vehicle	Year/Prod. Date	Engine	Transmission
---------	-----------------	--------	--------------

Technician Objectives

This worksheet will familiarize you with the critical safety procedures involved in working with a high-voltage hybrid system. You will understand all safety procedures and use all safety equipment.

Tools and Equipment

- High-Voltage Gloves
- Protective Eye Wear
- Emergency Response Guide
- Repair Manual
- EWD

Section 1: In Class - Hybrid Safety

1. Fill in the blanks in the following statements about hybrid safety.
 - a. Always follow the directions and warnings in the _____ and _____.
 - b. Always wear your high-voltage _____ and protective _____.
 - c. Remove the _____ from the 12V battery.
 - d. Put the _____ in your pocket and keep it under your control at all times.
 - e. Wait at least _____ minutes before inspecting any high-voltage system.
 - f. Always verify the _____ with a _____.

2. Using the Emergency Response Guide, explain how you could disable a hybrid vehicle if the ignition key or service plug were inaccessible?



SELF-ASSESSMENT 2-1
Hybrid Safety

Name:	Date:
-------	-------

Self-assessment Objectives

Review this sheet as you are doing the Hybrid Safety worksheet. Check off either category after completing the worksheet and instructor presentation. Ask the instructor if you have questions. The **Comments** section is for you to write notes on where to find the information, questions, etc.

I have questions

I know I can

Topic			Comment
Describe all safety procedures when working with the high voltages systems.			
Locate and list all safety equipment.			
Access the 12V battery.			
Access the high-voltage battery.			
Safely pull the service plug.			
Describe when the service plug needs to be removed.			



Notes



WORKSHEET 2-2
Data List Information – Test Drive

Vehicle	Year/Prod. Date	Engine	Transmission
---------	-----------------	--------	--------------

Worksheet Objectives

In this worksheet you will use the Diagnostic Tester to obtain and view relevant information and observe data lists while driving the vehicle. You will then relate this information to the different components and technologies of the hybrid system.

Tools and Equipment

- Vehicle
- Diagnostic Tester
- TIS Machine w/Tech View

Section 1 – HV ECU Data List

1. Connect the Diagnostic Tester to DLC3. Start the vehicle (READY light ON).
2. Go to **HV ECU, Data List**.
3. Create a **User Data** list with the following items:
 - MG1 REV
 - MG2 REV
 - MG1 TORQ
 - MG2 TORQ
 - POWER RQST
 - ENGINE SPD
 - VEHICLE SPEED

Note: Remember that when REV and TORQ are the same (both + positive or both – negative) the component is being used as a MOTOR. When REV and TORQ are different (ie. REV + & TORQ -) the component is a GENERATOR.

Section 2: In Shop - Hybrid Safety**Note: Bring your safety gloves and ERG to the shop.**

1. Remove the key from the vehicle and put it in your pocket. (The '04 and later smart key equipped vehicles will require the smart key system to be turned OFF first.)

2. Access the 12V auxiliary battery and remove the negative terminal. This assures what?

3. Locate the Service Plug. Put on your safety gloves and protective eye wear and remove the plug. What device or devices are integrated into the service plug assembly?

4. Re-install the service plug and allow another student to remove the plug wearing their gloves.

5. When each student has removed and re-installed the plug, use the Repair Manual, EWD, or TIS workstation to locate the IGCT Relay or HEV fuse in the vehicle. Write the location of the relay below.

6. When would you need to remove this relay?

Return vehicle to normal condition.

4. From a stop, lightly accelerate to 20 mph. Record the following values:

MG1 REV -	MG1 TORQ -
MG2 REV -	MG2 TORQ -
ENGINE SPD -	

5. Is MG1 being used as motor or a generator?

6. Is MG2 being used as a motor or generator?

7. Is the engine running?

8. Bring vehicle speed up to approximately 35 mph. Record the following values:

MG1 REV -	MG1 TORQ -
MG2 REV -	MG2 TORQ -
ENGINE SPD -	

9. Is MG1 being used as motor or a generator?

10. Is MG2 being used as a motor or generator?

11. Is the engine running?

12. Bring vehicle speed up to approximately 45 mph. Record the following values:

MG1 REV -	MG1 TORQ -
MG2 REV -	MG2 TORQ -
ENGINE SPD -	

13. Is MG1 being used as motor or a generator?

14. Is MG2 being used as a motor or generator?

15. Is the engine running?

SECTION 2 – Battery ECU Data List

1. With the Diagnostic Tester, select Battery ECU and enter the Data List.

2. Create a User Data list (use YES/NO keys to turn ON) with the following:

- BATTERY SOC
- BATT TEMP 1
- BATT TEMP 2
- BATT TEMP 3
- BATT TEMP 4
- BATT BLOCK V1
- BATT BLOCK V2

3. What is the battery SOC?

4. What is the AVG battery temperature?

5. What is the voltage of the battery blocks? V1 _____ V2 _____.

6. From a standing start accelerate to 20 mph. How is the temperature changing?

7. Is SOC (State Of Charge) changing?

8. Cruise at approx 35 mph. How is the temperature changing?

9. How is the SOC changing?

10. Accelerate full throttle to approx 45 mph. How is the temperature changing?

11. How is the SOC changing? Discharge _____ Charge _____.

Return to the shop.



SELF ASSESSMENT 2-2
Data List Information – Test Drive

Name:	Date:
-------	-------

Self-assessment Objectives

Review this sheet as you are doing the Data List Information worksheet. Check off either category after completing the worksheet and instructor presentation. Ask the instructor if you have questions. The **Comments** section is for you to write notes on where to find the information, questions, etc.

I have questions

I know I can

Topic			Comment
Create User Data from the HV ECU Data List.			
Determine if MG1 is being used as a motor or generator.			
Determine if MG2 is being used as a motor or generator.			
View the Battery ECU Data List.			
Determine the SOC (State of Charge).			



Notes

Section 3

High-Voltage Battery

Overview The sealed nickel-metal hydride (Ni-MH) battery technology developed for the hybrid system provides both high power density and excellent longevity. The hybrid system controls charge and discharge rates to keep the HV battery at a constant State of Charge (SOC).

HV Battery Layout

The HV Battery, Battery ECU and SMR (System Main Relay) are enclosed in a single case located in the luggage compartment behind the rear seat.

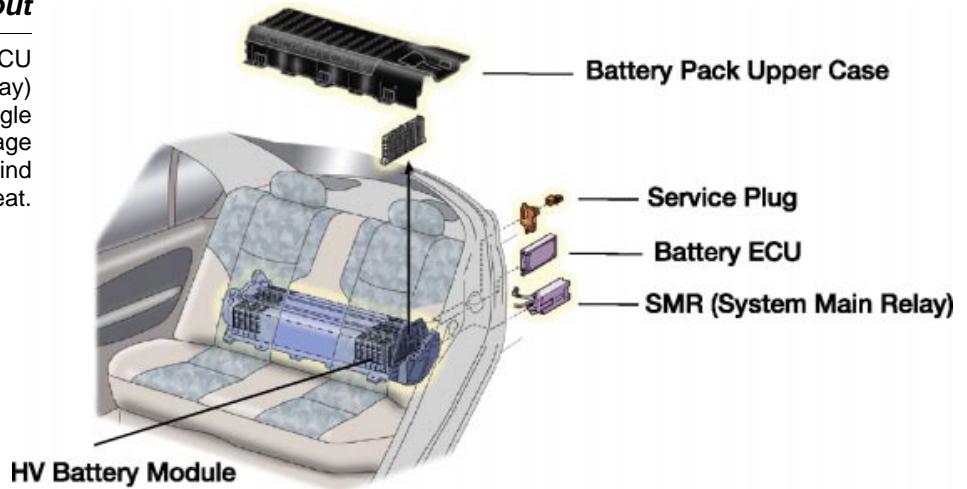

Figure 3.1

T071f301c

Power Cable The power cable is a high-voltage, high-amperage cable that connects the HV battery with the inverter and the inverter with MG1 and MG2. In the '04 & later Prius, the power cable also connects the inverter with the A/C compressor.

The power cable is routed under the rear seat, through the floor panel, along the under-the-floor reinforcement, and connects to the inverter in the engine compartment. The 12V DC wiring harness follows a similar route from the auxiliary battery to the front of the vehicle.

The power cable is shielded to reduce electromagnetic interference. For identification purposes, the high-voltage wiring harness and connectors are color-coded orange to distinguish them from ordinary low-voltage wiring.

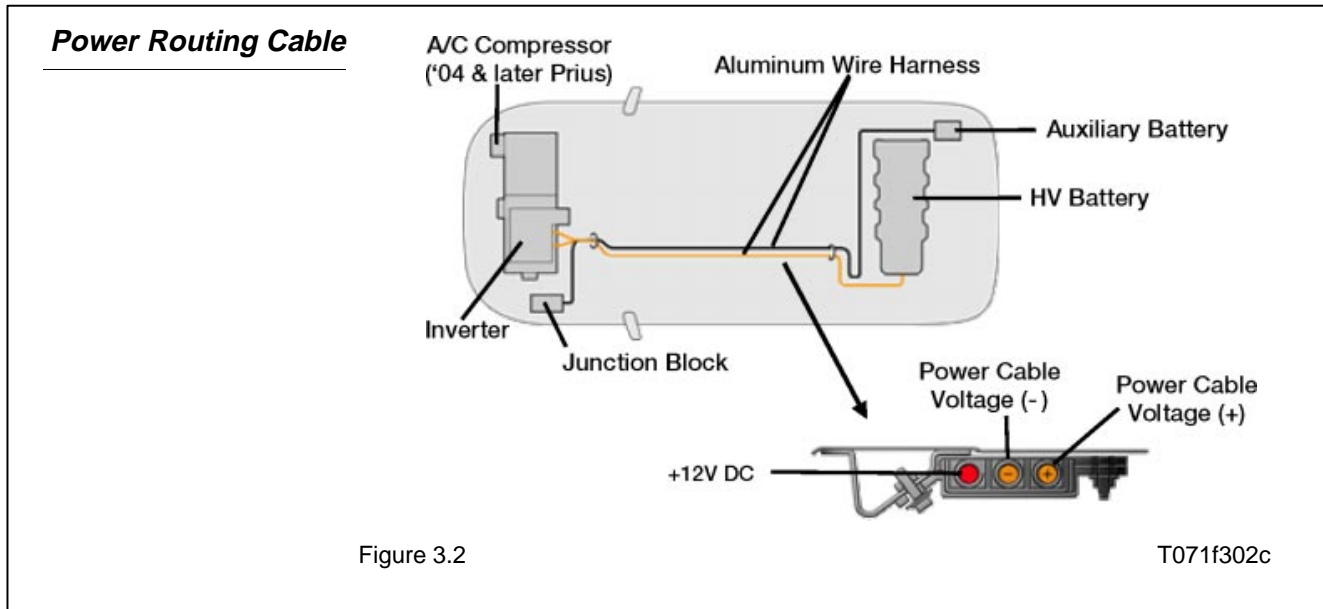

HV - Nickel-Metal Hydride Battery

The HV battery pack contains six nickel-metal hydride 1.2V cells that are connected in series to form one module.

In the '01-03 Prius, 38 modules are divided into two holders and connected in series. Thus, the HV battery contains a total of 228 cells and has a rated voltage of 273.6V.

In the '04 and later Prius, 28 modules are connected for a rated voltage of 201.6V. The cells are connected in two places to reduce the internal resistance of the battery.

The electrode plates in the HV battery are made of porous nickel and metal hydride alloy.

NOTE

For battery recycling information, please refer to the Warranty Policy and Procedure manual.

<i>HV Battery Pack Information</i>	HV Battery Pack	'04 Prius and Later	'01-'03 Prius
Battery pack voltage		201.6V	273.6V
Number of Ni-MH battery modules in the pack		28	38
Number of cells		168	228
Ni-MH battery module voltage		7.2V	←

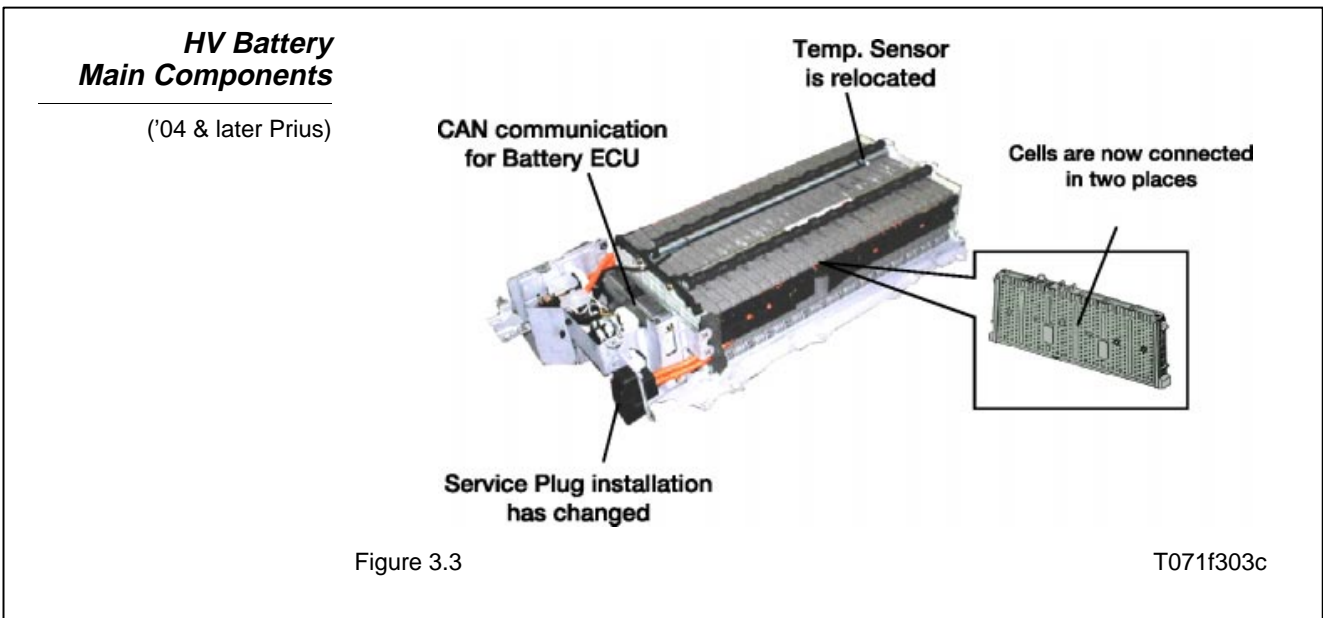

Battery ECU The battery ECU provides the following functions:

- It estimates the charging/discharging amperage and outputs charge and discharge requests to the HV ECU so that the SOC can be constantly maintained at a center level.
- It estimates the amount of heat generated during charging and discharging, and adjusts the cooling fan to maintain HV battery temperature.
- It monitors the temperature and voltage of the battery and if a malfunction is detected, can restrict or stop charging and discharging to protect the HV battery.

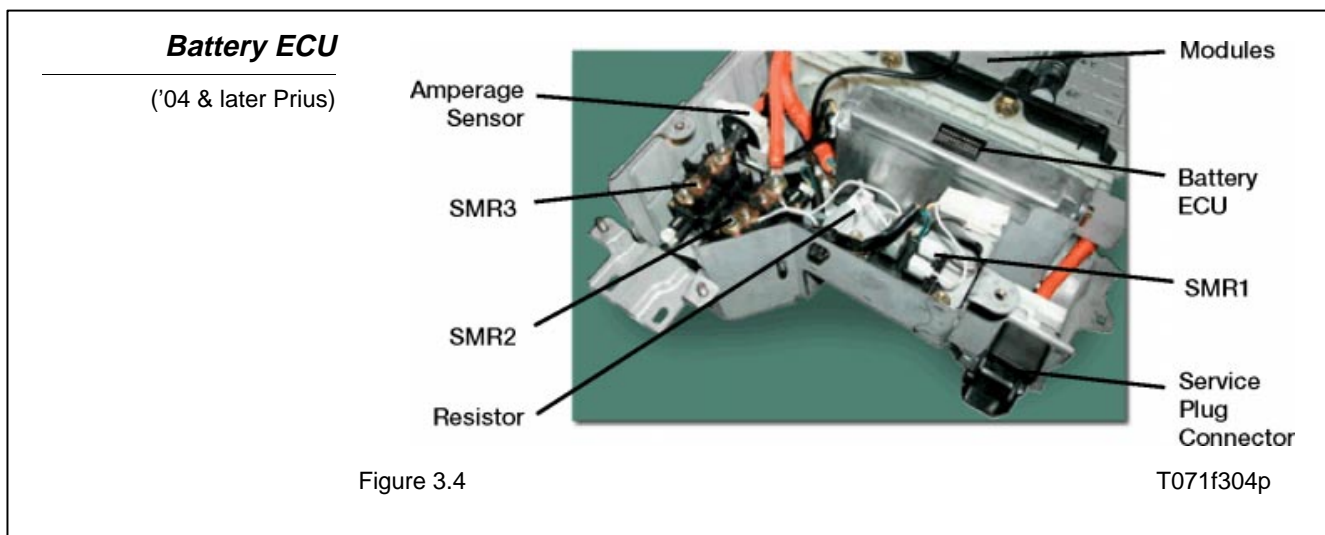

State Of Charge (SOC) The battery ECU constantly monitors HV battery temperature, voltage and amperage. It also checks for leaks in the HV battery.

While the vehicle is in motion, the HV battery undergoes repetitive charge/discharge cycles as it becomes discharged by MG2 during acceleration, and charged by the regenerative brake during deceleration. The Battery ECU estimates the charge/discharge amperage and outputs charge/discharge requests to the HV ECU to maintain the SOC at a median level.

The target SOC is 60%. When the SOC drops below the target range, the battery ECU informs the HV ECU. The HV ECU then signals the engine ECM to increase power to charge the HV battery. If the SOC is below 20%, the engine is not producing power.

Delta SOC The normal, low to high SOC deviation is 20%. If the Delta SOC exceeds 20%, this means that the HV battery ECU cannot correct or maintain the SOC difference within the acceptable range.

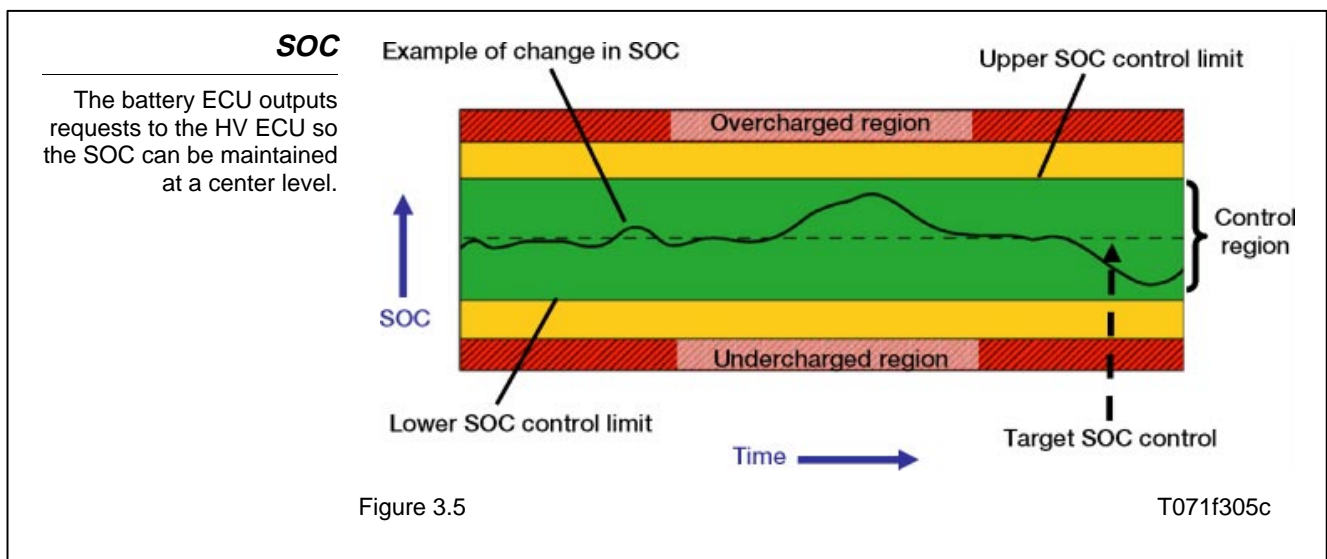

System Main Relay (SMR) The System Main Relay (SMR) connects and disconnects power to the high-voltage circuit based on commands from the HV ECU. A total of three relays (one for the negative side and two for the positive side) are provided to ensure proper operation.

When the circuit is energized, SMR1 and SMR3 are turned ON. The resistor in line with SMR1 protects the circuit from excessive initial current (called 'inrush' current). Next, SMR2 is turned ON and SMR1 is turned OFF, allowing current to flow freely in the circuit.

When de-energized, SMR2 and SMR3 are turned OFF in that order and the HV ECU verifies that the respective relays have been properly turned OFF.

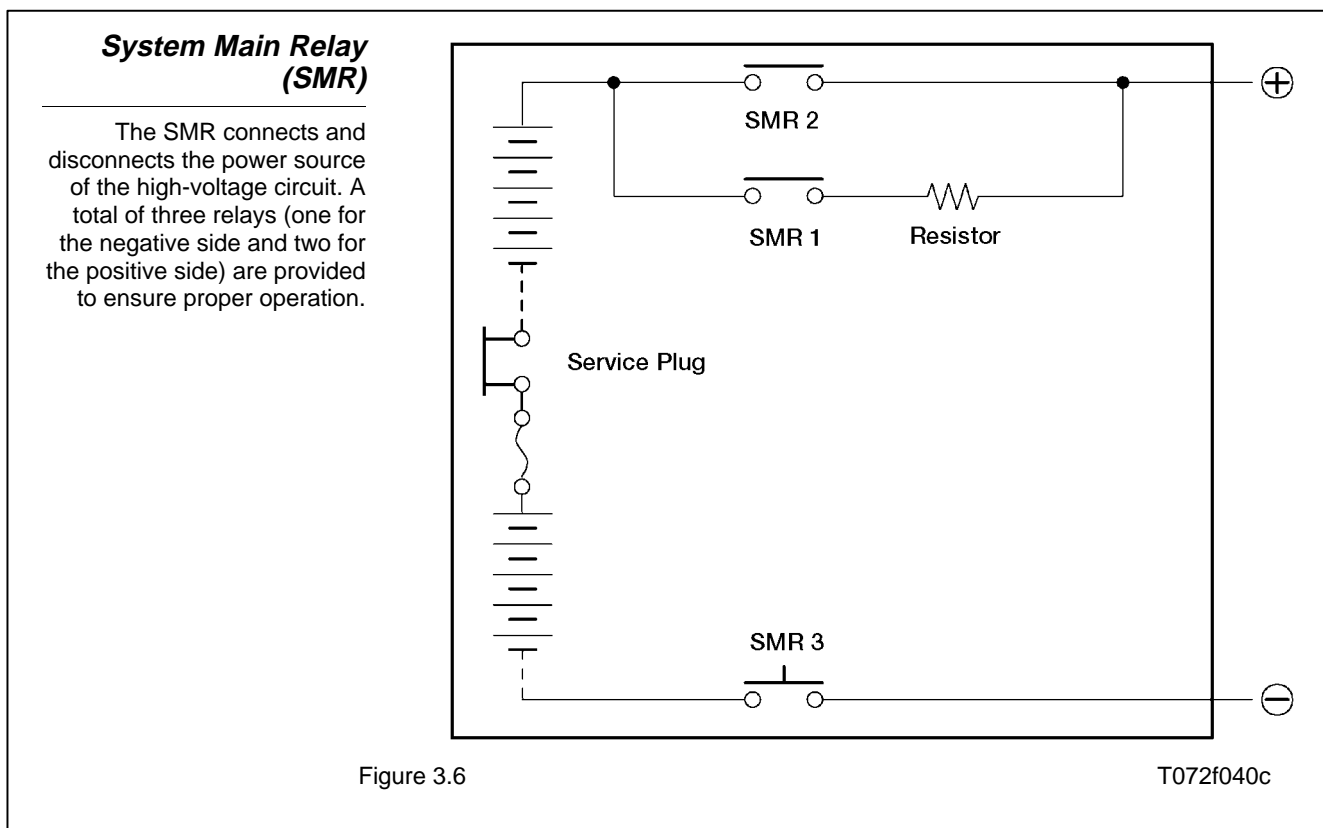

Service Plug When the service plug is removed the high-voltage circuit is shut OFF at the intermediate position of the HV battery.

The service plug assembly contains a safety interlock reed switch. Lifting the clip on the service plug opens the reed switch, shutting OFF the SMR.

The main fuse for the high-voltage circuit is inside the service plug assembly.

NOTE

For safety reasons, you must always turn the vehicle OFF before removing the service plug.

HV Battery Cooling System

The battery ECU detects battery temperature via three temperature sensors in the HV battery and one intake air temperature sensor. Based on those readings, the battery ECU adjusts the duty cycle of the cooling fan to maintain the temperature of the HV battery within the specified range.

The battery ECU keeps the fan OFF or running at LO if:

- The A/C is being used to cool the vehicle.
- Some margin is left in the temperature of the battery.

HV Battery Cooling System

('01-'03 Prius)

Air Intake

Blower Assembly

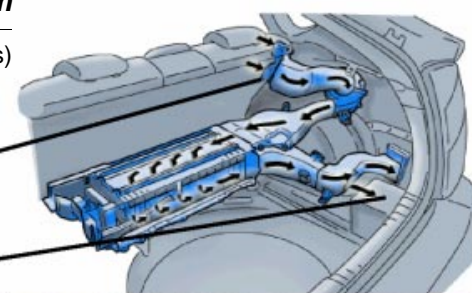

Air Intake Temp Sensor



Battery Temp Sensor



Figure 3.9

T071f309p

HV Battery Cooling System

('04 & later Prius)

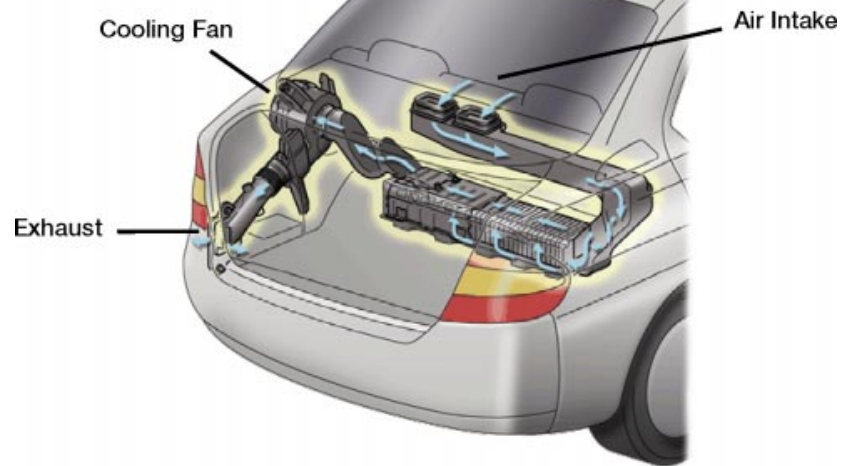

Figure 3.10

T071f310c

Auxiliary Battery The Prius uses an Absorbed Glass Mat (AGM) 12V maintenance free auxiliary battery. This 12V battery powers the vehicle's electrical system similar to a conventional vehicle. The battery is grounded to the metal chassis of the vehicle and vented to ambient (outside) air with a tube.

This battery is very sensitive to high-voltage. When charging the auxiliary battery you should use the Toyota approved charger, because a standard battery charger does not have the proper voltage control and may damage the battery. If the approved charger is not available you may use a trickle charger if the amperage is kept below 3.5 A.

The battery should be removed from the vehicle during charging. However, it is safe to jump-start the Prius from either the battery or the jump-start terminal under the hood. This will allow the vehicle's charging system to restore the battery to normal SOC.

If the vehicle will not be used for more than two weeks, disconnect the 12V battery to prevent it from discharging. Always make sure that all doors are properly closed and that the interior lights are OFF, especially overnight. These situations will quickly deplete the 12V battery.

Auxiliary Battery

In glass mat batteries, the electrolyte is trapped in separators to reduce the amount of hydrogen gas released when the battery is charged.

Glass mat batteries are sealed and the electrolyte cannot be replaced.

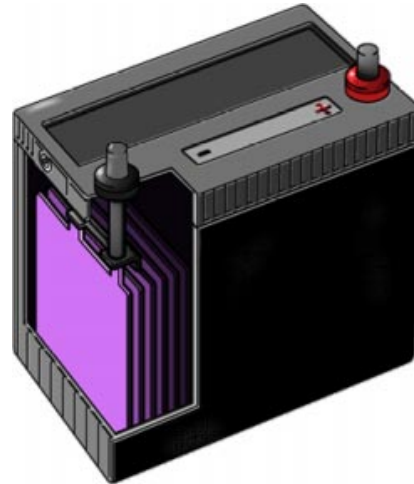

Figure 3.11

T071f311c

Auxiliary Battery Charging

('04 & later Prius)

There is a remote access B + terminal in the main junction block under the hood, so it is no longer necessary to remove interior trim pieces to gain access to the battery.

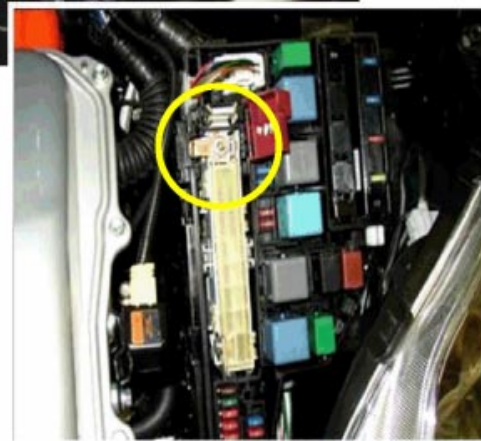

Figure 3.12

T071f312p



Notes



WORKSHEET 3-1

Hybrid Diagnostic Trouble Codes

Vehicle	Year/Prod. Date	Engine	Transmission
---------	-----------------	--------	--------------

Worksheet Objectives

In this worksheet you will diagnose hybrid malfunctions by viewing DTCs, Information Codes, and the HV ECU Data List.

Tools and Equipment

- Vehicle
- Diagnostic Tester
- Printer
- Repair Manual or TIS

Section 1: Hybrid Diagnosis

1. When starting the vehicle (READY light ON) do any warning lights illuminate? If so, which ones?

2. Connect the Diagnostic Tester to DLC3. Select **Codes All** to check all the ECUs.

3. How many systems are checked when using Codes All?

4. List the systems that show **NG** (No Good).

5. Now view the Information Codes by pressing enter on the systems that say NG, then press enter again. Highlight the number next to **INFORMATION** and press enter.

Section 3

6. Use the Repair Manual or TIS to look up the DTC and Information Code in order to find what part of the system is affected. List this information below.

7. Is there any information in the **HV ECU Data List** that can help you diagnose the vehicle? If so, print and highlight the information.
8. After diagnosing the vehicle, clear the codes and return to the classroom.

Hint: To clear DTCs, you must exit out of CODES ALL and enter each section individually.



SELF-ASSESSMENT 3-1
Hybrid Diagnostic Codes

Name:	Date:
-------	-------

Self-assessment Objectives

Review this sheet as you are doing the Hybrid DTC Diagnosis worksheet. Check off either category after completing the worksheet and instructor presentation. Ask the instructor if you have questions. The **Comments** section is for you to write notes on where to find the information, questions, etc.

I have questions

I know I can

Topic			Comment
Locate vehicle warning lights.			
View Codes All using the Diagnostic Tester.			
View the Information Codes.			
Use TIS & Repair Manual to research these codes.			
View the HV ECU Data List.			
Clear Codes.			



Notes

Section 4

Engine

Overview The 1NZ-FXE is one of two power sources for the Prius. The 1NZ-FXE is a 1.5 liter inline 4-cylinder engine with VVT-i (Variable Valve Timing with intelligence) and ETCS-i (Electric Throttle Control System with intelligence). The 1NZ-FXE includes a number of modifications that help balance performance, fuel economy and clean emissions in hybrid vehicles.

One unique aspect of the 1NZ-FXE is its Atkinson cycle valve timing, which allows the engine to decrease emissions by varying the relationship between the compression stroke and the expansion stroke. Another feature incorporated on '04 & later models is a special coolant heat storage system that recovers hot coolant from the engine and stores it in an insulated tank where it stays hot for up to three days. Later, an electric pump pre-circulates the hot coolant through the engine to reduce HC emissions normally associated with a cold start.

Engine

The 1NZ-FXE is a 1.5 liter inline 4-cylinder engine.



Figure 4.1

T071f401p

Engine Specifications		Model	'04 Prius	'03 Prius
		Engine Type	1NZ-FXE	←
No. of Cyls. & Arrangement	4-Cylinder, In-line	←		
Valve Mechanism	16-Valve DOHC, Chain Drive (with VVT-i)	←		
Combustion Chamber	Pentroof Type	←		
Manifolds	Cross-Flow	←		
Fuel System	SFI	←		
Displacement	cm ³ (cu. in.)	1497 (91.3)	←	
Bore x Stroke	mm (in.)	75.0 x 84.7 (2.95 x 3.33)	←	
Compression Ratio		13.0 : 1	←	
Max Output	(SAE-NET)	57 kw @ 5000 rpm (76 HP @ 5000 rpm)	52 kw @ 4500 rpm (70 HP @ 4500 rpm)	
Max Torque	(SAE-NET)	111 N·m @ 4200 rpm (82 ft·lbf @ 4200 rpm)	←	
Valve Timing	Intake	Open	18° ~ -15° BTDC	18° ~ -25° BTDC
		Close	72° ~ 105° ABDC	72° ~ 115° ABDC
	Exhaust	Open	34° BBDC	←
		Close	2° ATDC	←
Firing Order		1-3-4-2	←	
Research Octane Number		91 or higher	←	
Octane Rating		87 or higher	←	
Engine Service Mass * (Reference)	kg (lb)	86.1 (189.8)	86.6 (190.9)	
Oil Grade		API SJ, SL, EC or ILSAC	API SH, SJ, EC or ILSAC	
Tailpipe Emission Regulation		SULEV	←	
Evaporative Emission Regulation		AT-PZEV, ORVR	LEV-II, ORVR	

*: Weight shows the figure with the oil and engine coolant fully filled.

Figure 4.2

T071f402

VVT-i and Atkinson Cycle

VVT-i allows the engine control system to independently adjust intake valve timing. The 1NZ-FXE uses this ability to move between conventional valve timing and Atkinson cycle valve timing, varying the effective displacement of the engine.

In an Atkinson cycle engine, the intake valve is held open well into the compression stroke. While the valve is open, some of the cylinder volume is forced back into the intake manifold. This creates an effective reduction in engine displacement. By using the VVT-i system to continuously adjust intake valve timing between Atkinson cycle valve timing and conventional valve timing, the engine can maximize fuel efficiency whenever possible while still producing maximum power when required.

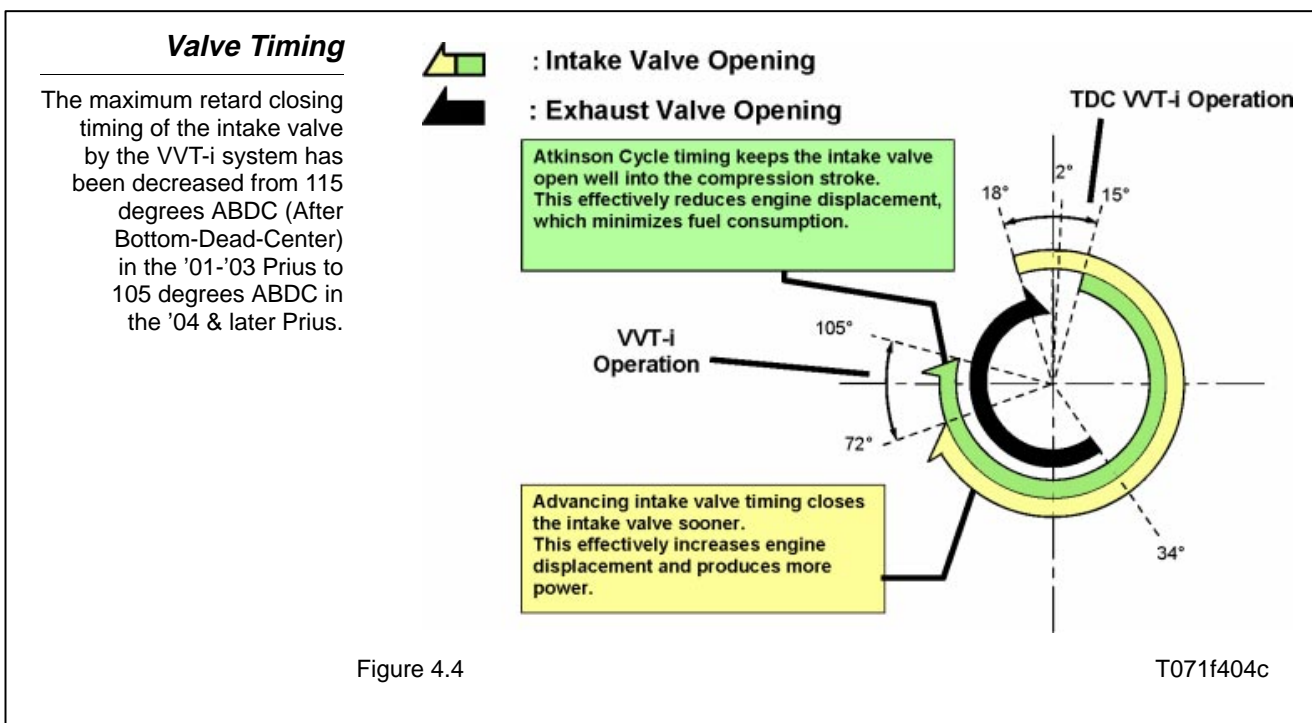

Intake Manifold

The intake manifold has a large surge tank that accommodates the air forced back into the manifold during the compression stroke of the Atkinson cycle engine.

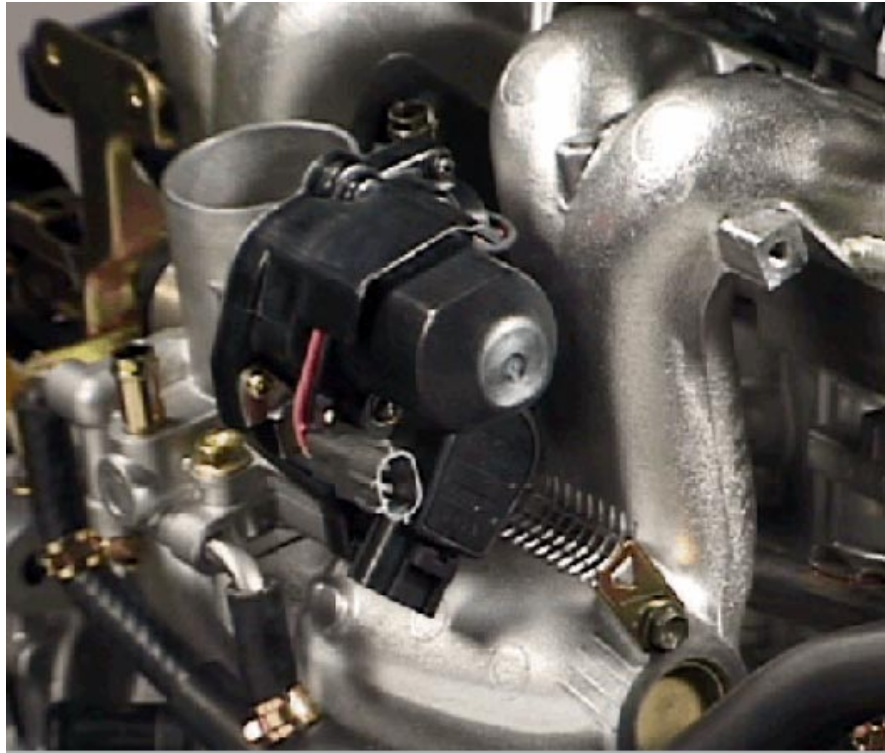

Figure 4.5

T071f405p

Intake Manifold Because some of the air is forced back into the intake manifold during the compression stroke of the Atkinson cycle, the 1NZ-FXE's intake manifold includes a large surge tank to accommodate the extra volume. Also, the length of the intake manifold's intake pipe has been shortened to improve air efficiency and the intake pipes have been integrated midstream to reduce weight. Finally, the throttle body has been positioned down flow in the center of the surge tank to achieve uniform intake air distribution.

ETCS-i With ETCS-i on the Prius, there is no accelerator cable connected to the throttle valve. Instead, the ECM looks at the output of the Accelerator Pedal Position Sensor to determine driver demand, and then calculates the optimal throttle valve opening for the current driving condition. It then uses the throttle control motor to control the throttle valve angle.

Engine Control System Sensors

- Mass Airflow Meter** The Mass Airflow Meter determines the amount of air flowing into the intake manifold. To measure airflow, a heated platinum wire is positioned in the intake air stream just above the throttle body. The temperature of the hot wire is maintained at a constant value by controlling the current flow through the hot wire. Incoming air tends to cool the hot wire. As airflow increases, current flow through the wire must be increased to maintain the hot wire's set temperature. This current flow is then measured and reported to the ECM as the output voltage of the airflow meter.
- Intake Air Temperature Sensor** The Intake Air Temperature Sensor is built into the Mass Airflow Meter and uses an NTC (Negative Temperature Coefficient) thermistor to monitor intake air temperature. As intake air temperature increases, the thermistor's resistance and the signal voltage to the ECM decrease.
- Engine Coolant Temperature Sensor** The Engine Coolant Temperature Sensor is located in the engine block and uses an NTC thermistor monitor engine coolant temperature. As coolant temperature increases, the thermistor's resistance and the signal voltage to the ECM decrease.
- Accelerator Pedal Position Sensor** The Accelerator Pedal Position Sensor is mounted on the accelerator pedal assembly. Two Hall ICs are used to detect accelerator pedal position. Due to the characteristics of the Hall ICs, different signals are output depending on whether the pedal is being pressed or released. The HV ECU receives the signals and compares them to ensure that there is no malfunction.
- Throttle Position Sensor** The Throttle Position Sensor is mounted on the throttle body and converts throttle valve angle into two voltage signals (VTA and VTA2). The ECM compares the two voltages to ensure there is not malfunction.
- The ECM uses this information to calculate throttle valve opening, then actuates the throttle control motor to adjust throttle valve position accordingly.
- Idle Speed Control** ETCS-i adjusts the throttle valve angle to control idle speed. No separate idle speed control system is required. The system includes idle-up control during cold engine operation, intake air volume control to improve engine startability, and load compensation for changes such as when the A/C is turned ON or OFF.

Knock Sensor The Knock Sensor is mounted on the cylinder block and detects detonation or knocking in the engine. The sensor contains a piezoelectric element that generates a voltage when cylinder block vibrations due to knocking deform the sensor. If engine knocking occurs, ignition timing is retarded until the knock is suppressed.

Crankshaft Position Sensor The Crankshaft Position Sensor (NE signal) consists of a toothed signal plate mounted on the crankshaft and an inductive pick up coil. The signal plate has 34 teeth, with one gap created by missing teeth, so the sensor generates a 34-pulse waveform for every crankshaft revolution. Since this is an inductive sensor, both the frequency and amplitude of the generated signal increase with increasing engine rpm. The ECM uses the NE signal to determine engine rpm and detect misfires.

Camshaft Position Sensor The Camshaft Position Sensor (G2 signal) consists of a signal plate with a single tooth that is mounted on the exhaust camshaft and a pick up coil. The sensor generates one-pulse waveform for every revolution of the exhaust camshaft. Since this is an inductive sensor, both the frequency and amplitude of the generated signal increase as engine rpm increases. The ECM uses the G2 signal to determine the position of the number one piston for the ignition firing order.

Heated O2 Sensors On the '01-'03 Prius, the sensors include:

- Bank 1, Sensor 1*
- Bank 1, Sensor 2*

*Sensor 1 - refers to the sensor ahead of the catalytic converter. This sensor measures the oxygen content of the engine exhaust gases. The ECM uses this input to adjust fuel trim.

*Sensor 2 - refers to the sensor after the catalytic converter. This sensor is used to measure catalyst efficiency.

The O2 Heater Control maintains the temperature of the O2 Sensors to increase accuracy of detection of the oxygen concentration in the exhaust gas.

Air/Fuel Ratio Sensor On the '04 and later Prius, the Bank 1 Sensor 1 O2 sensor is replaced by an A/F sensor. The A/F sensor detects the air/fuel ratio over a wider range, allowing the ECM to further reduce emissions.

The Prius uses a planar (flat) A/F sensor. The sensor and heater on a planar sensor are narrower than those on a conventional cup sensor. This allows the heater to heat the alumina and zirconia more quickly, accelerating sensor activation.

Exhaust System

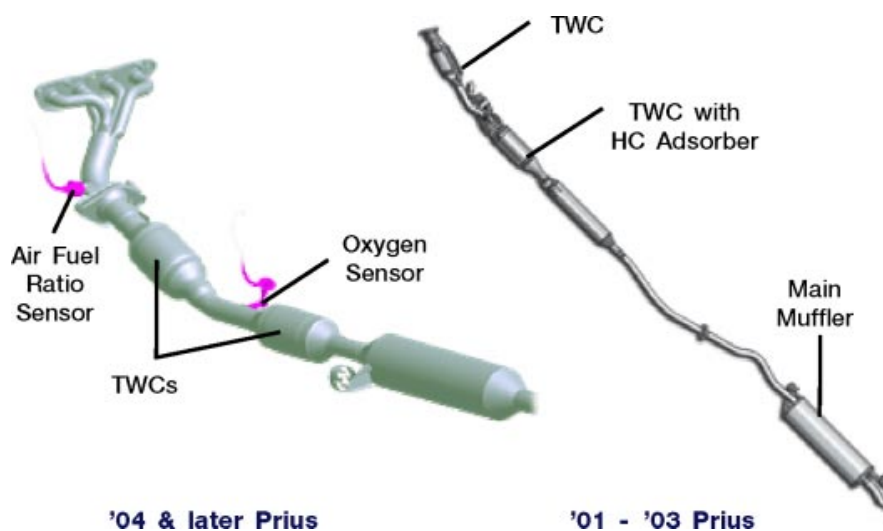

Figure 4.6

T071f406c

HC Adsorber and Catalyst System (HCAC)

('01-'03 Prius)

The HCAC system adsorbs and retains unburned hydrocarbons (HC) produced by the engine during and following a cold start. Once the engine has warmed up, the hydrocarbons are released and purged through the warm three-way catalyst. This improves exhaust emissions at low temperatures.

HCAC - Cold Engine

When the engine is started, the ECM signals the HCAC VSV to apply vacuum to the HCAC actuator, closing the bypass valve. Exhaust gases pass through the HC adsorber where HC is stored until the temperature of the HC adsorber rises. This prevents HC from being emitted when catalyst temperatures are low.

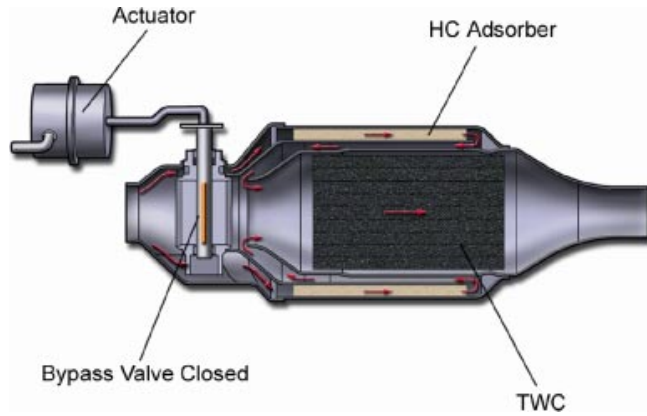

Figure 4.7

T072f207c

HCAC - Purge

When the TWC reaches operating temperature the VSV closes and the bypass valve opens. Stored HC is now purged and flows through the TWC where it is oxidized.

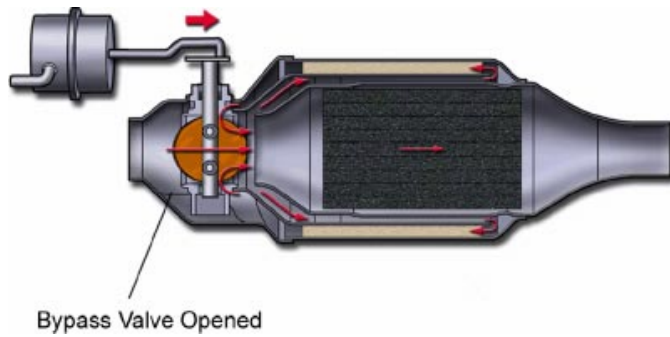

Figure 4.8

T072f208c

HCAC - Scavenge During Deceleration

During deceleration, the VSV is turned on, closing the bypass valve. This scavenges any HC that remains in the HC adsorber.

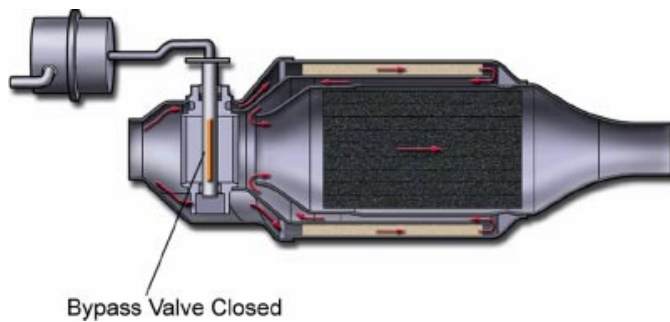
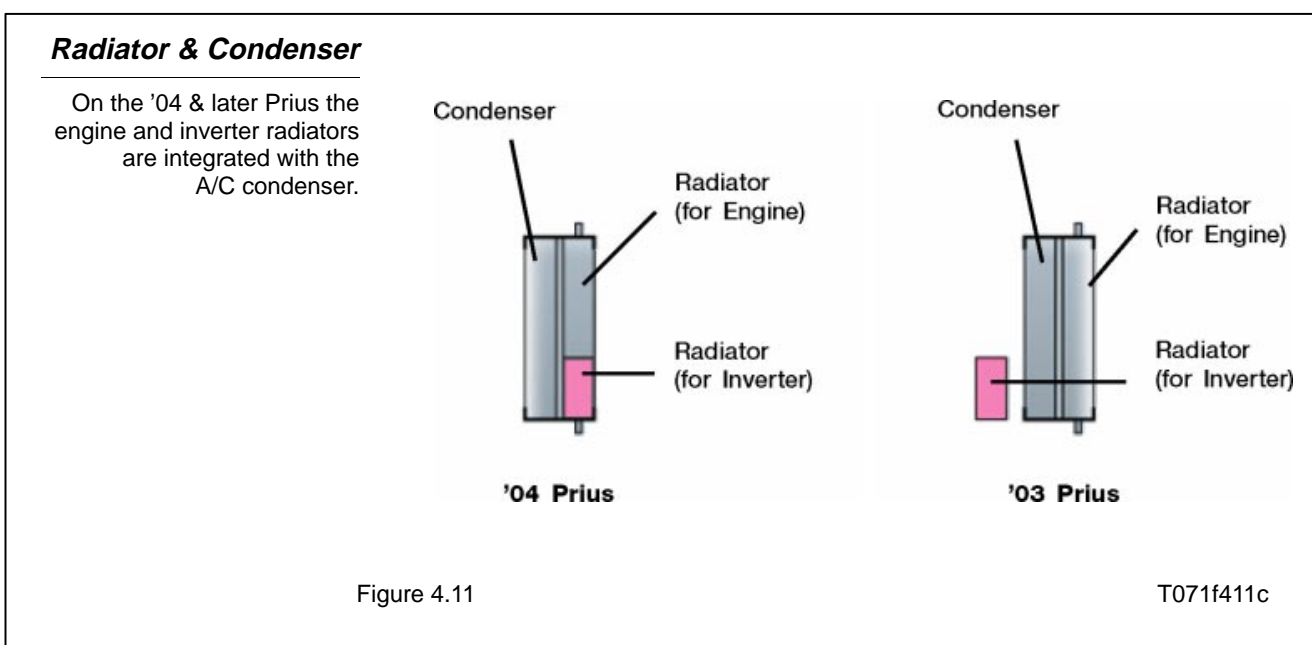
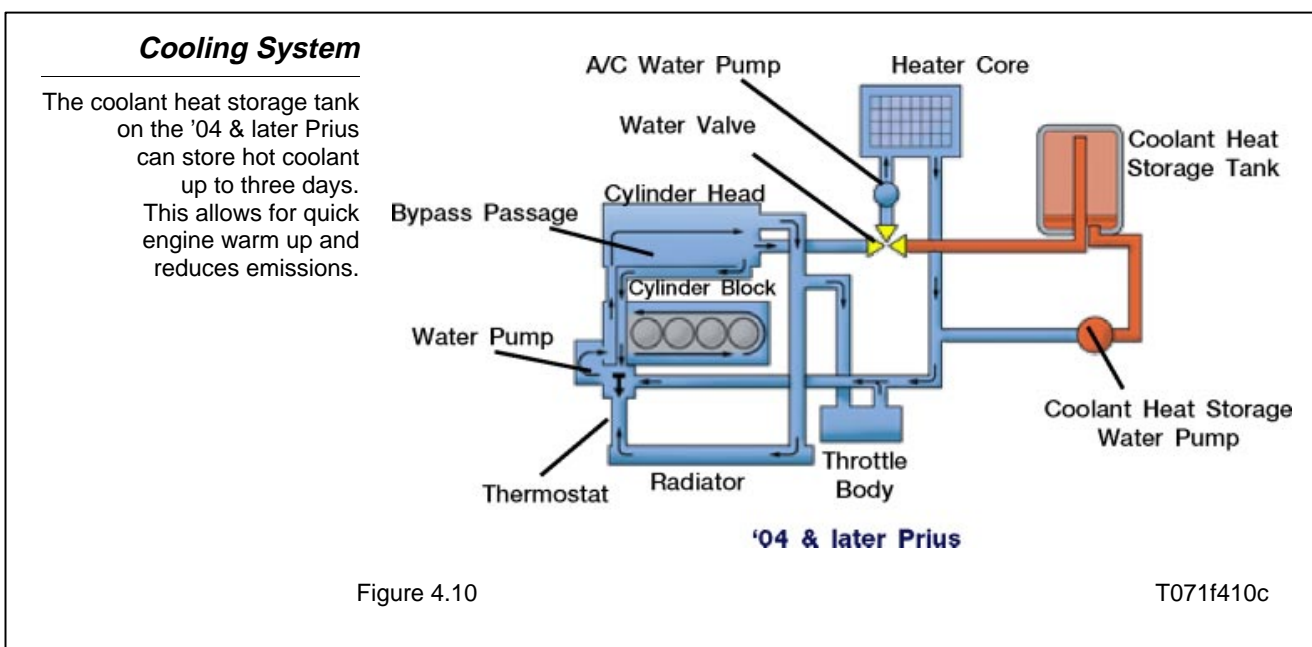

Figure 4.9

T072f209c

Cooling System The 1NZ-FXE uses a pressurized, forced-circulation cooling system. A thermostat with a bypass valve located on the water inlet housing controls coolant flow to maintain suitable temperature distribution in the cooling system.

The radiator for the engine and the A/C condenser are integrated to minimize space requirements. On the '04 & later Prius, the radiator for the inverter cooling system has also been integrated into the same unit.



Coolant Heat Storage Starting with the '04 Prius, the cooling system includes a Coolant Heat Storage Tank that can store hot coolant at 176 degrees Fahrenheit for up to three days. When starting a cold engine, the system uses an auxiliary water pump to force the hot coolant into the engine. This 'preheating' of the engine reduces HC exhaust emissions.

Coolant Heat Storage Tank

The storage tank is a large vacuum insulated container located near the left front bumper.

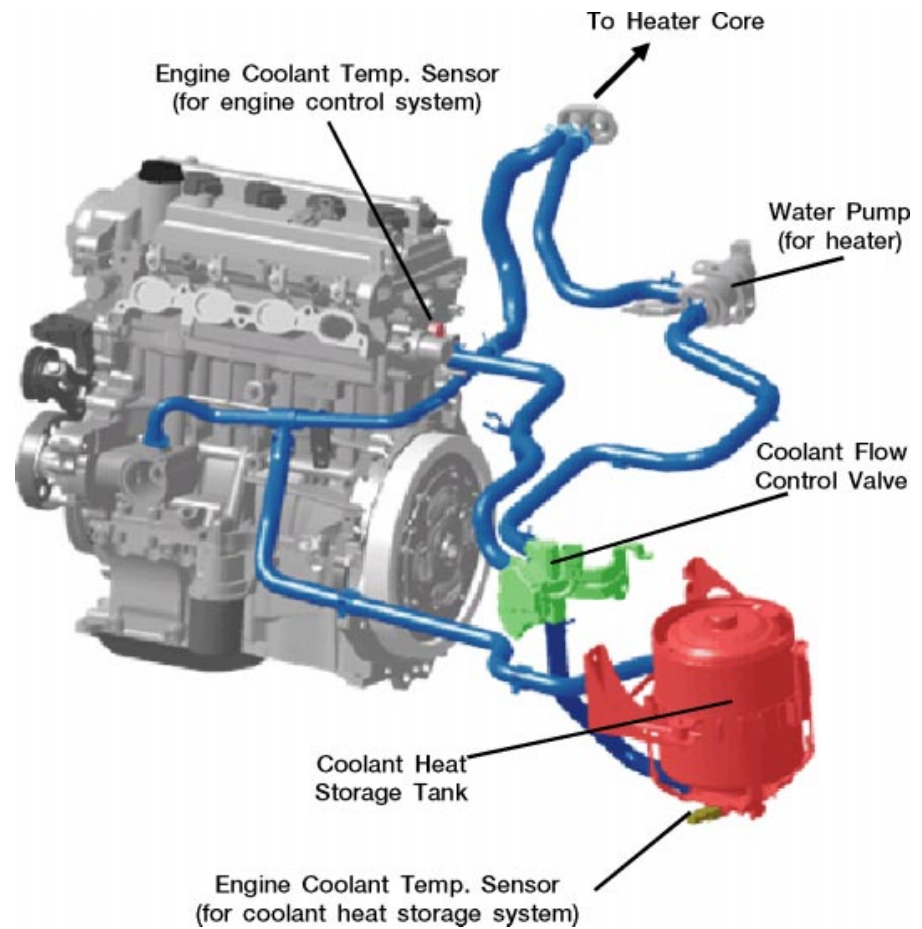

Figure 4.12

T072f203c

Coolant Heat Storage Tank

Coolant Drain Plug

Outlet Temp Sensor



Figure 4.13

T072f204p

Coolant Heat Storage Tank

Water Pump



Figure 4.14

T072f205p

SERVICE TIP

When servicing the coolant system on the '04 & later Prius:

- Disconnect the coolant heat storage water pump connector to prevent circulation of the coolant and prevent possible injury.
- Drain the engine coolant.
- When refilling, operate the coolant heat storage water pump to help the inflow of coolant into the tank.

Rotary Water Valve

Switches between three positions to control flow of coolant in and out of coolant heat storage system.

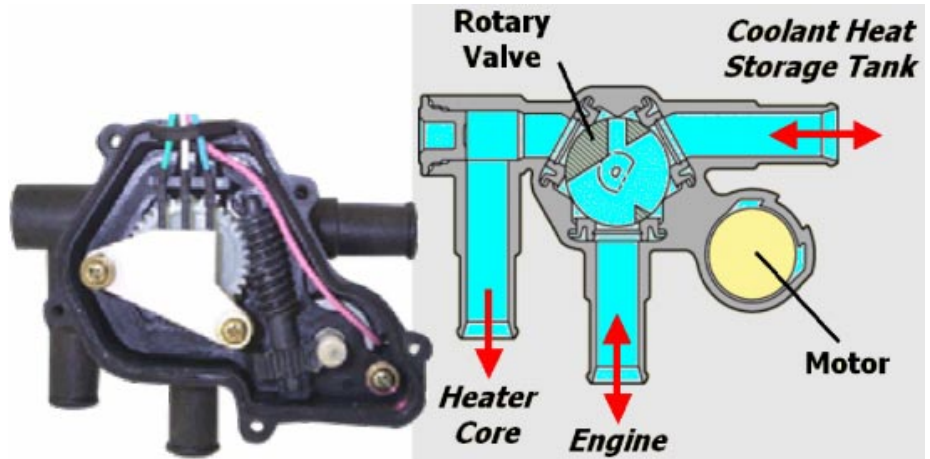

Figure 4.15

T072f206c

Coolant Heat Storage Tank Operation

Preheat Operation.

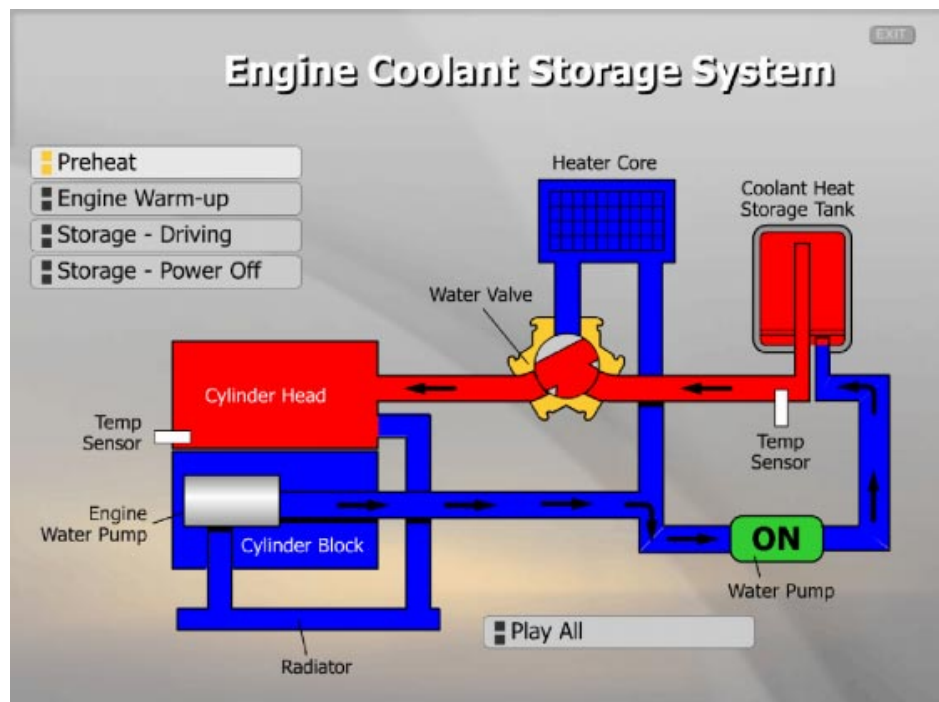

Figure 4.16

T071f416c

Coolant Heat Storage Tank Operation

Engine Warm-up Operation.

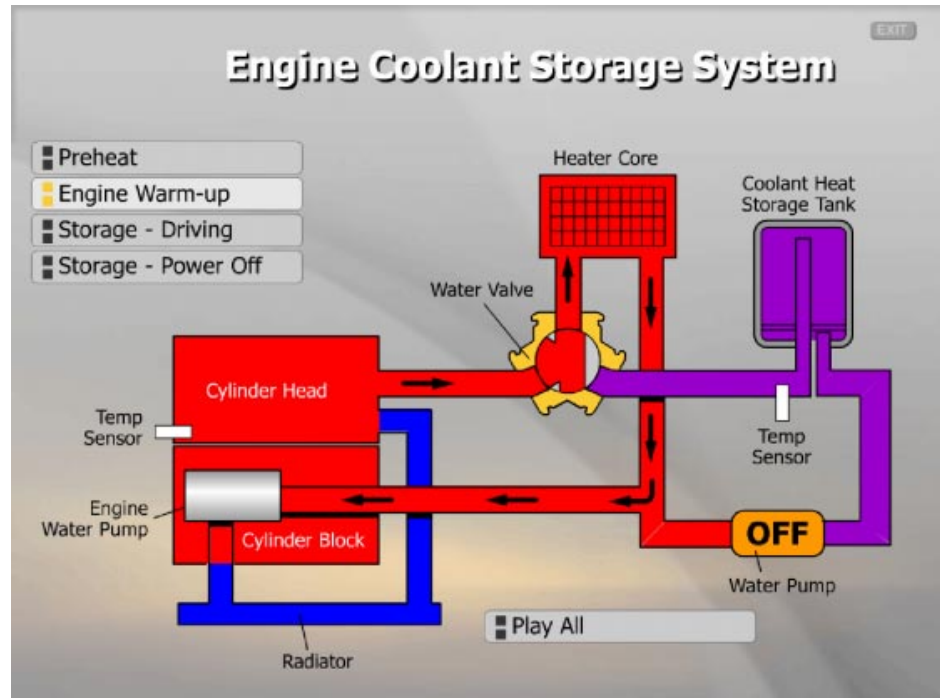

Figure 4.17

T071f417c

Coolant Heat Storage Tank Operation

Storage Operation (during driving)

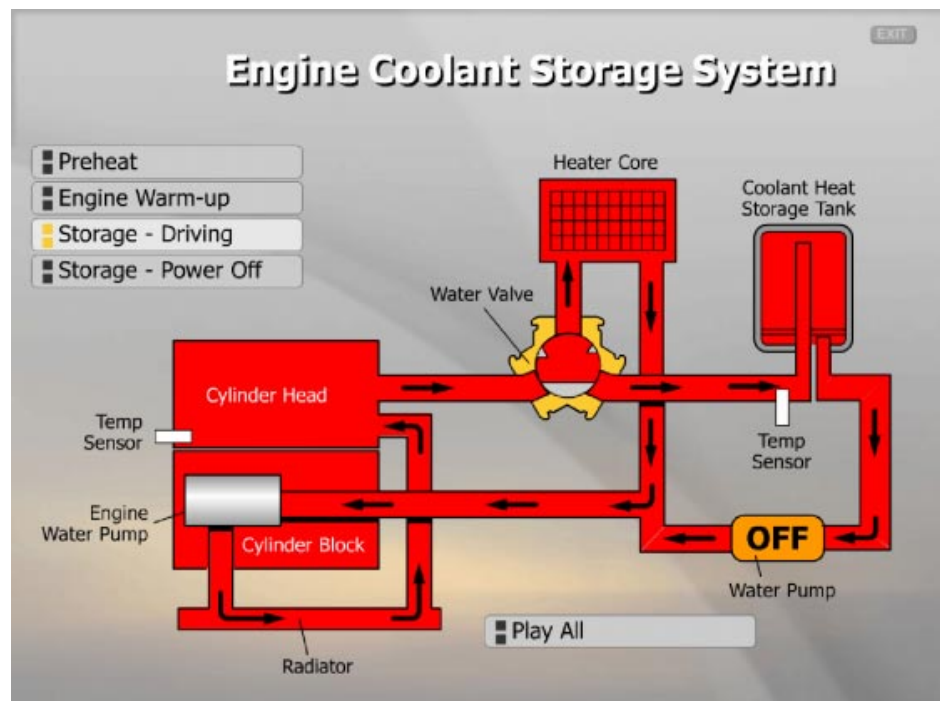

Figure 4.18

T071f418c

Coolant Heat Storage Tank Operation

Storage Operation (IG-OFF)

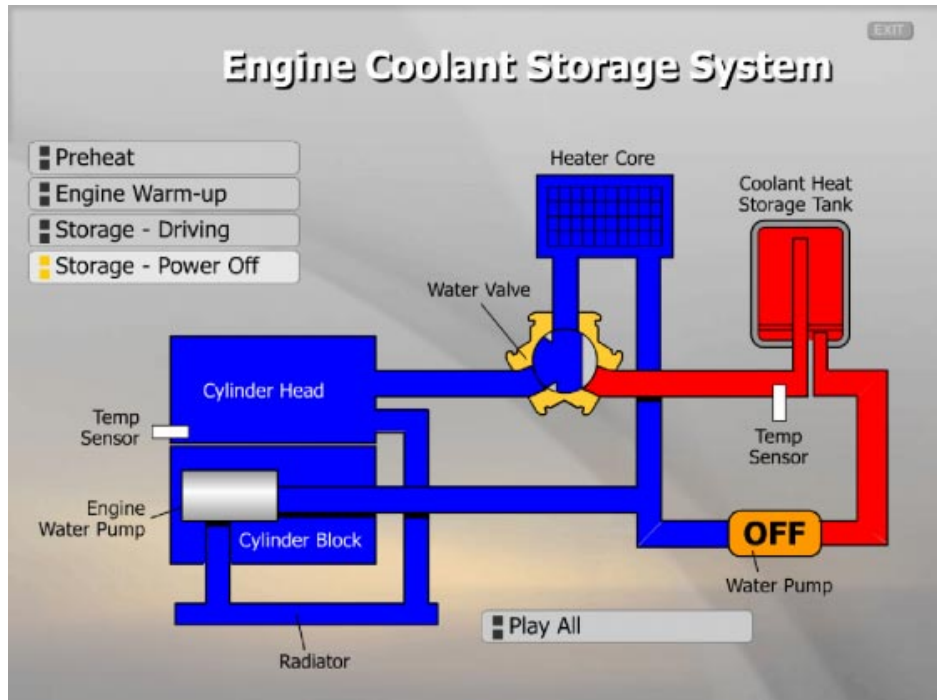

Figure 4.19

T071f419c

Bladder Fuel Tank

The bladder fuel tank reduces the amount of fuel lost to evaporation. To prevent evaporation the fuel is stored inside a flexible resin storage tank sealed within a metal outer tank. The resin tank expands and contracts with the volume of the fuel, so the space into which fuel can evaporate is minimized. This approach dramatically reduces evaporative emissions.

Fuel Bladder

The resin bladder in the Prius fuel tank expands and contracts with the changing quantity of fuel.

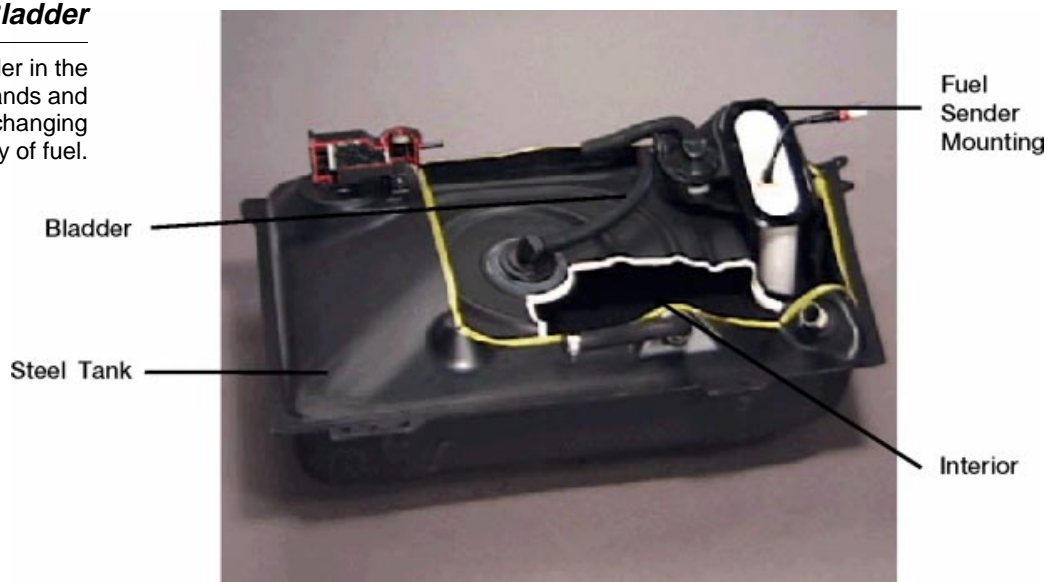

Figure 4.20

T071f420p

Fuel Gauge The direct acting fuel gauge is located in the sealed inner tank. This gauge consists of a pipe surrounded by a coil. A magnet attached to a float in the pipe moves up and down with changes in fuel level causing a change in the coil's magnetic field. This results in a slight difference in potential at either end of the coil that is read by the Meter ECU.

NOTE

The fuel pump is integrated with the fuel tank and cannot be serviced separately.

Fuel Gauge Sender

Direct-acting fuel gauge, consisting of a magnetic float, is located in the sub tank.

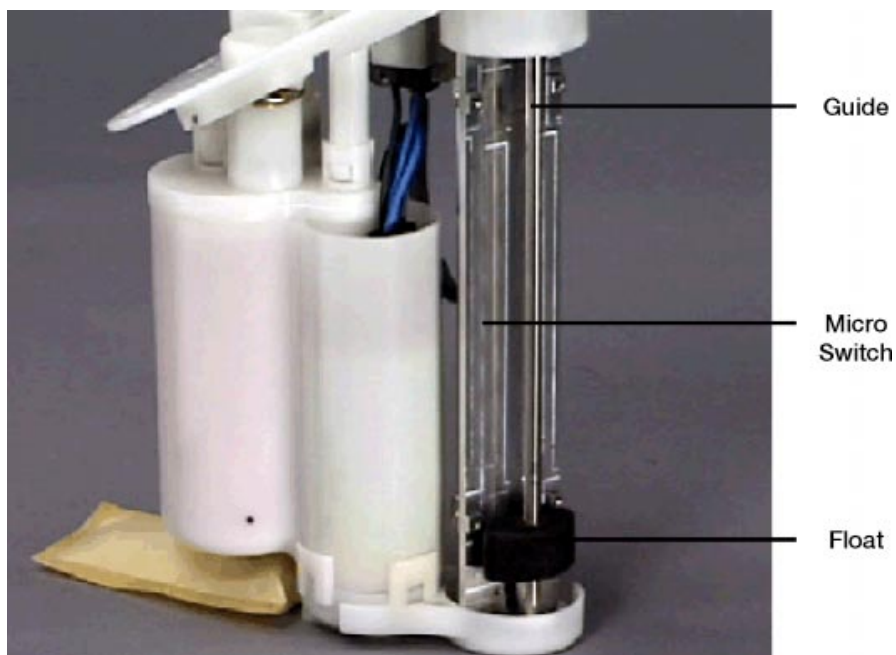
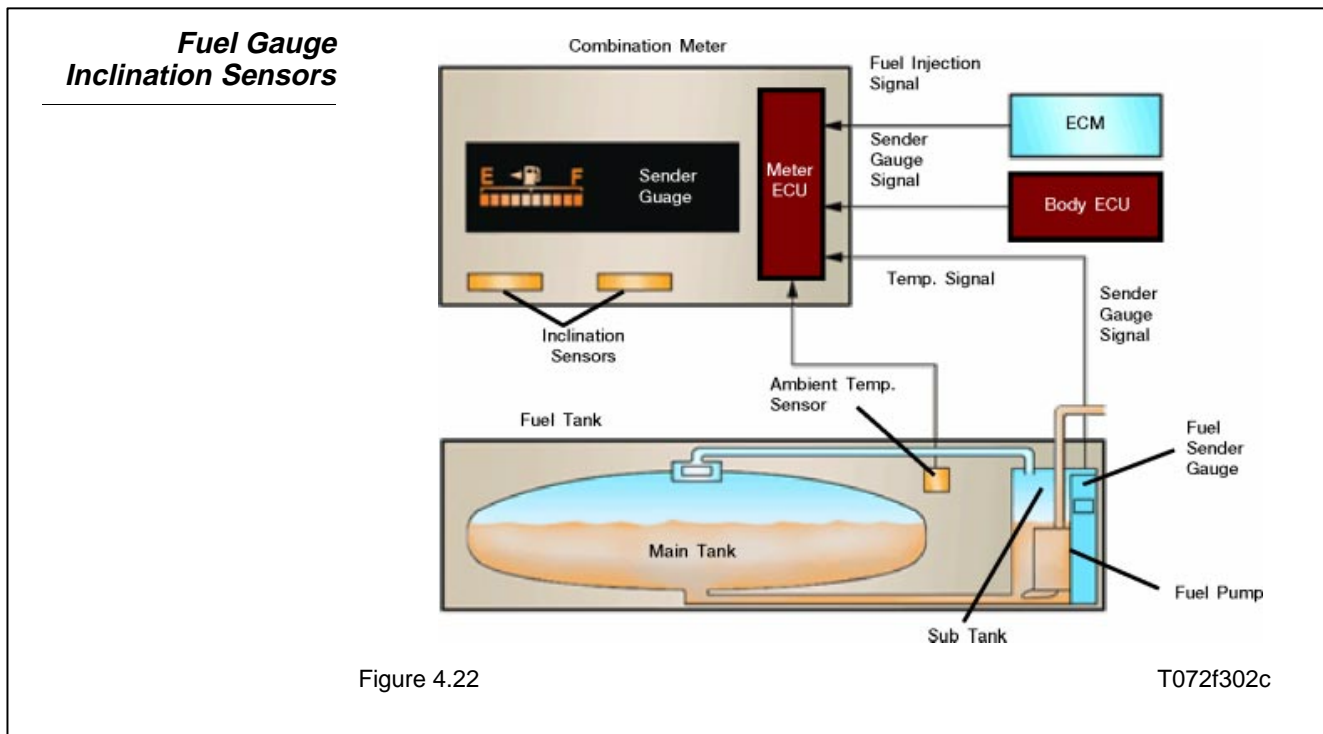

Figure 4.21

T071f421p

Inclination Sensors There are two inclination sensors located in the meter ECU that detect vehicle longitudinal and latitudinal inclination to correct the fuel level calculation. Corrections are made based on the signals from the inclination sensors and the ambient temperature sensor located in the fuel tank.

The inclinometer must be reset if the driver can only pump a few gallons of gas into his/her tank, or the vehicle runs out of gas with three or four bars left on the fuel meter. The inclinometer must also be reset if the Prius is refilled on an excessive slope or if the fuel gauge becomes inaccurate. Please refer to the Prius Repair Manual for the inclinometer calibration procedure.

**NOTE**

Unlike conventional vehicles, on a hybrid vehicle the engine may start many times in a single drive cycle. This increases potential “hot soak” issues.

Fuel Capacity Fuel capacity can vary for several reasons:

- Temperature - At low ambient temperatures, the resin material used for the flexible inner tank may lose some of its ability to expand during refueling. If the outside temperature is 14°F, the size of the tank is reduced by approximately 5 liters.
- Fuel Nozzle Fit - The bladder fuel tank uses gas pump pressure to help inflate the bladder during refueling, so the Prius fuel filler neck is equipped with a rubber seal to ensure a tight seal between the pump nozzle and the filler neck. If the gas pump nozzle is dented, scratched, or gouged the poor fit between the pump nozzle and the filler neck can reduce fuel tank capacity.

NOTE

Overfilling (trying to force additional fuel into the tank) pushes excess fuel into the EVAP system. This may cause EVAP DTCs and may even require the replacement of some EVAP system components.

Energy Monitor The Energy Monitor, which includes a historical bar graph and total trip fuel economy (MPG), is very accurate. Multiple, comparative calculations are performed by several computers.

Fuel usage and fuel economy are calculated by monitoring fuel injector duration and operating frequency. The ECU compares these values with miles traveled to calculate miles per gallon.

The battery ECU closely monitors energy consumption in Watts. By calculating the amount of energy spent, recovered, and stored, the computer can calculate the required fuel burn. Fuel required to create this amount of energy is compared against the engine ECU fuel injection calculation to insure accuracy.

Driving pattern, speed, and load characteristics are stored in the HV ECU as “Historical Data.” Historical Data is used to further refine the MPG calculation. This data takes about three to six weeks to accumulate if the battery is disconnected or the HV ECU is replaced.

Fuel Type & Octane Rating Use only 87 Octane unleaded gasoline in the Prius. The Prius has a smaller fuel tank opening to help prevent nozzle mix-ups. At a minimum, the gasoline used should meet the specifications of ASTM D4814 in the United States. Do not use premium gasoline. It may causes starting problems with the Prius. There is no gas mileage benefit when using premium gas!

EVAP System Checks To check for leaks in the EVAP system the Prius introduces purge vacuum into the entire system, then looks for changes in pressure. Any loss of vacuum indicates a leak in the system.

To detect EVAP leaks from the vapor reducing fuel tank, the Prius uses the density method. This method uses an O2 sensor to measure HC density in the exhaust gases. Added HC from a leak will cause a reduction in exhaust oxygen content.

EVAP Parts Location

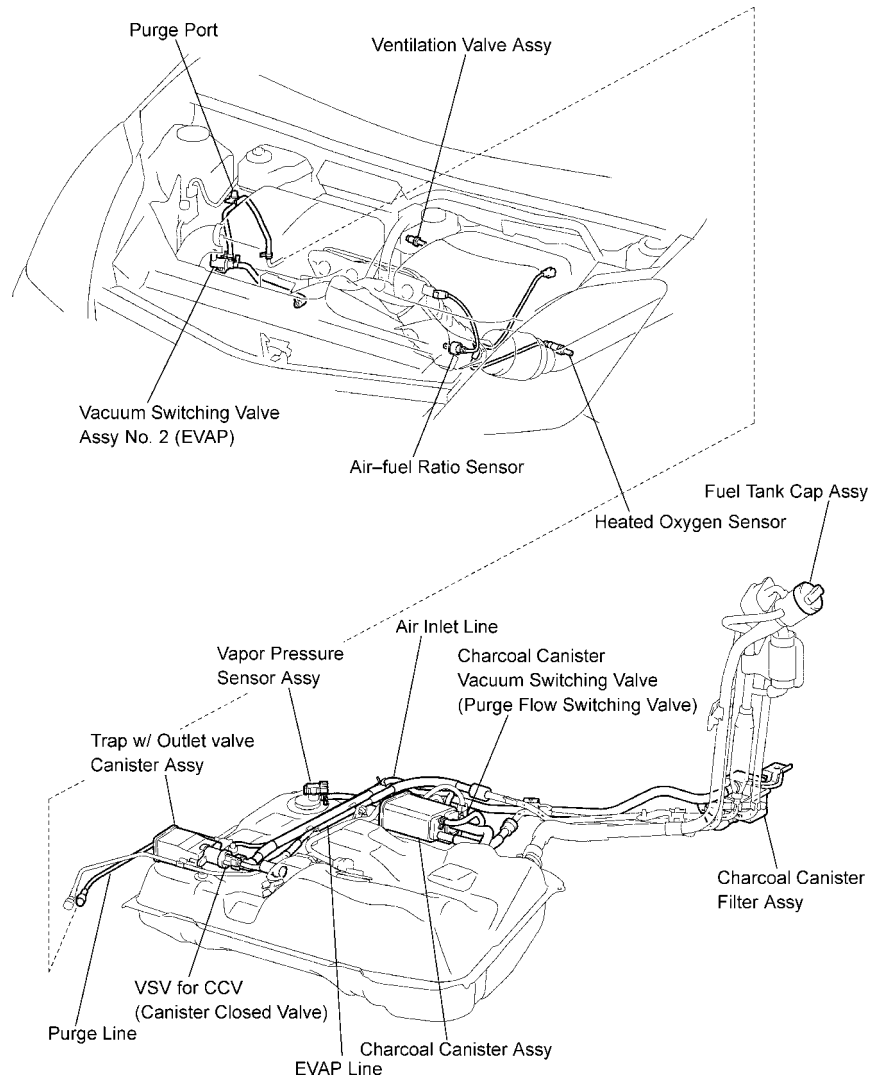

Figure 4.23

T072f020c

EVAP Components The EVAP system includes the following main components:

- Canister Closed Valve VSV – This **normally open** valve is located between the fresh air line and the fuel tank. This Vacuum Switching Valve (VSV) stops airflow into the EVAP system to seal the system and enable leak detection. It is also known as the CAN CTRL VSV or the CCV VSV.
- Purge Flow Switching Valve VSV – Allows vacuum from the EVAP VSV (or Purge VSV) to flow through the canister. When activated by the ECM during internal fuel bladder leak detection, it switches airflow from the canister to the outer tank bladder only. This VSV is also called the Tank Bypass VSV on the Diagnostic Tester.
- EVAP (Alone) VSV – Is used to control engine vacuum to the EVAP system in order to remove stored hydrocarbons from the charcoal canister. It is also used for system leak detection and may be referred to as the Purge VSV.
- Vapor Pressure Sensor (VPS) - The ECU provides a 5V signal and ground to the Vapor Pressure Sensor. The VPS sends a voltage signal back to the ECU, which varies between 0.1 – 4.9V in response to tank pressure.
- Fuel Cutoff Valve - Causes the filler nozzle to shut off when the fuel tank is full to prevent overfilling.
- Refuel Check Valve - Anti-siphon valve that prevents fuel from entering EVAP system lines. Also called Tank Over Fill Check Valve.

NOTE

The following VSVs are referred to by several different names in some Toyota repair information:

- CAN CTRL VSV - Canister Closed Valve or CCV VSV
- Tank Bypass VSV - Purge Flow Switching Valve
- EVAP VSV (Alone) - Purge VSV
- Refuel Check Valve - Tank Over Fill Check Valve

EVAP Control Components

On the '04 & later Prius, the fresh air inlet has been relocated from the air cleaner to the vicinity of the fuel inlet.

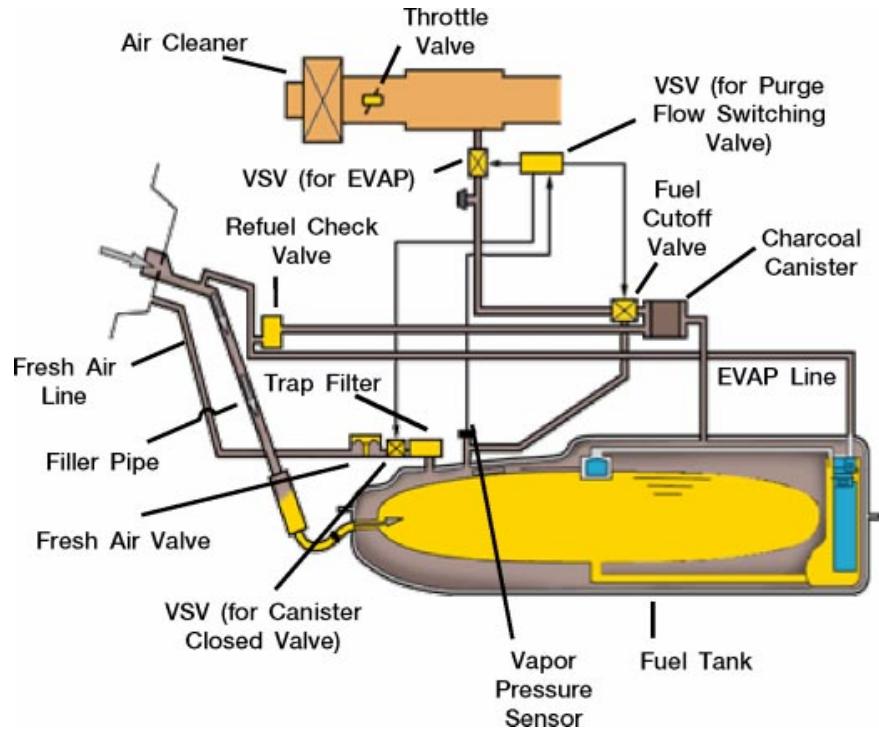
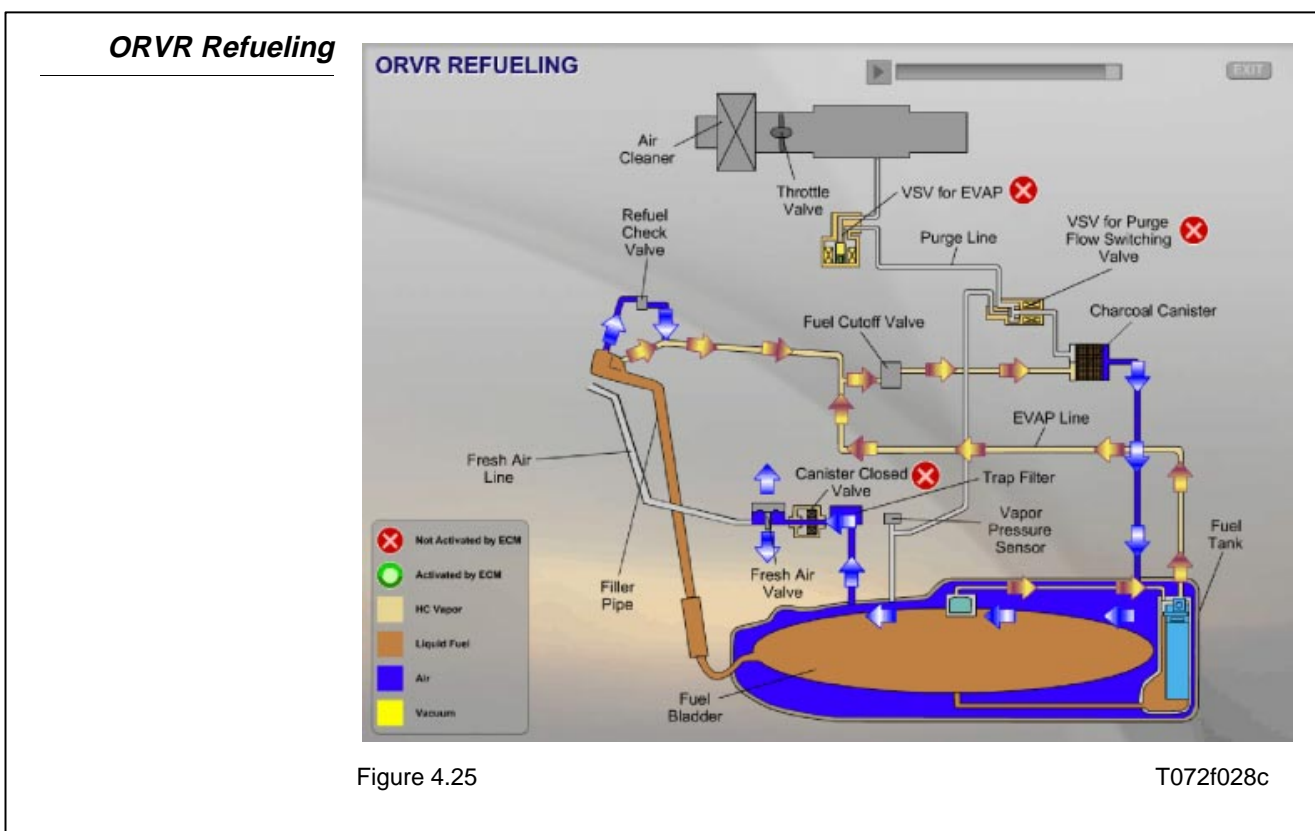

Figure 4.24

T071f424c

Operation - ORVR Refueling When refueling, the engine is OFF and EVAP VSV is CLOSED (OFF). The resin bladder expands as fuel enters, so there is virtually no vapor space above the fuel. Hydrocarbon (HC) vapor flows from the secondary tank and fuel pump through the EVAP line to the charcoal canister where the HC is absorbed and stored.

Airflows from the charcoal canister to the airspace between the metal outer tank and bladder and to the Canister Closed Valve. The Canister Closed Valve (CCV) is OPEN, allowing air to exit from the Fresh Air Valve. The Refuel Check Valve and Fuel Cutoff Valve work together to prevent overfilling and liquid fuel from entering the charcoal canister.



Purging During normal purge operation the engine is running and the ECM duty cycles the EVAP VSV ON and OFF allowing vacuum from the intake manifold to pull air through the EVAP system. The Purge Flow Switching Valve is OFF, opening the connection between the charcoal canister and the EVAP VSV. HC vapor flows from the charcoal canister to the EVAP VSV and into the intake manifold.

The Canister Closed Valve (CCV) is OPEN, allowing fresh air to enter from the air cleaner and flow through the airspace between the metal outer tank and bladder and up to the charcoal canister. As this air passes through the canister, it purges the HC.

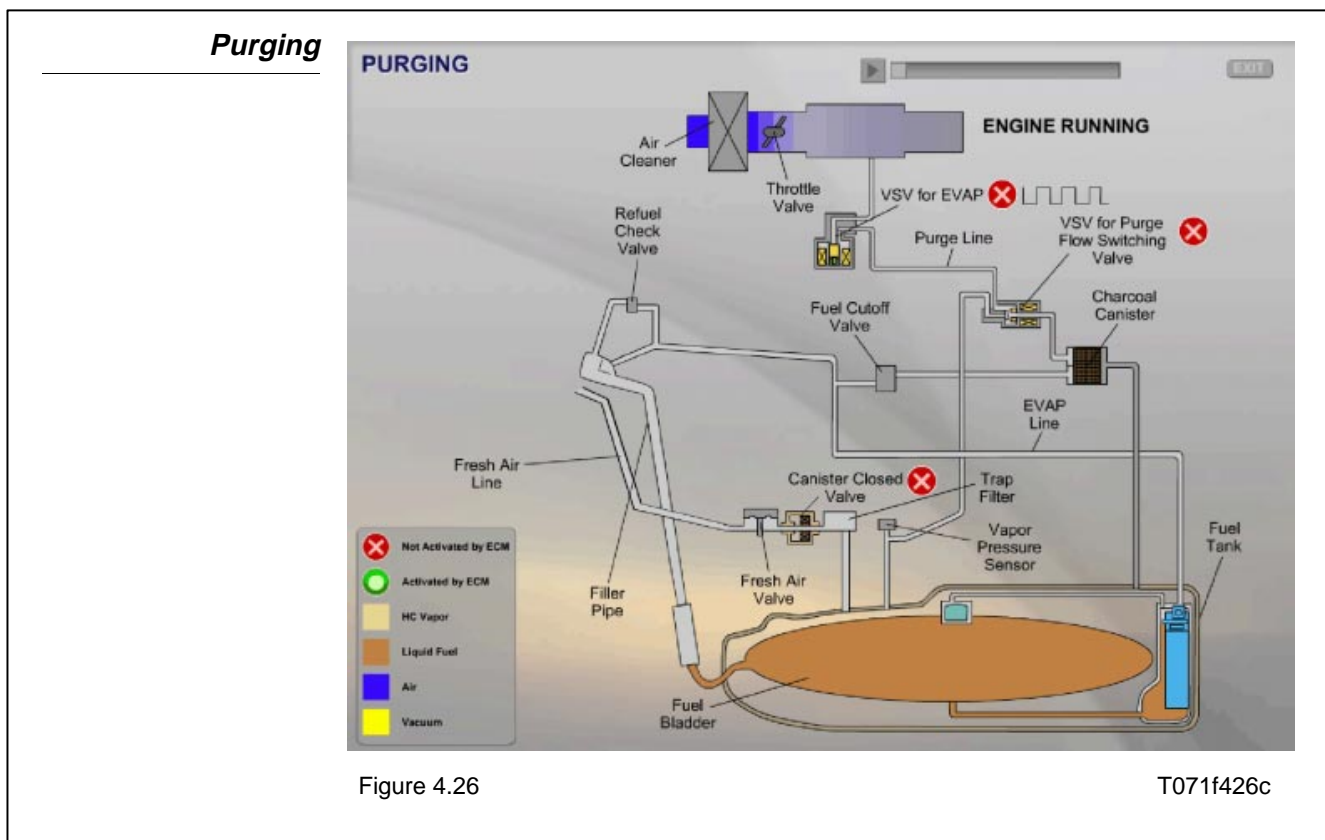



WORKSHEET 4-1
Out of Gas Condition

Vehicle	Year/Prod. Date	Engine	Transmission
---------	-----------------	--------	--------------

Worksheet Objectives

This worksheet will give you additional experience diagnosing hybrid system diagnostic codes and identifying a common “Out of Gas” condition.

Tools and Equipment

- Vehicle
- Diagnostic Tester
- Repair Manual or TIS

NOTE: DO NOT operate the vehicle with a SOC (State of Charge) below 35%!!! Reinstall the Circuit Opening Relay and cycle the key to recharge the battery. Do not leave the parking lot area!!

Section 1 – Battery Data List

1. Connect the Diagnostic Tester to DLC3.
2. Access the **Battery ECU Data List**.
3. Create a **User Data** list (use YES/NO keys to turn ON) with the following:
 - BATTERY SOC
 - BATT TEMP 1
 - BATT TEMP 2
 - BATT TEMP 3
 - BATT TEMP 4
 - BATT BLOCK V1
 - BATT BLOCK V2

4. What is the SOC (State of Charge)?

5. Using the Repair Manual, locate the Circuit Opening Relay. Leave the engine running and remove the Circuit Opening Relay to shut OFF the fuel pump. What happened to the engine?

6. After the circuit-opening relay is removed, turn the ignition OFF and attempt to restart the vehicle. Describe what happens.

7. Drive under normal acceleration and observe the SOC. What is the SOC doing as the temperature increases?

8. What is the SOC%?

9. Approximately how long can you operate the vehicle only on the HV Battery?

10. Exit out of the Data List and enter back into **OBD/MOBD**. Select **CODES ALL**.

11. On the Diagnostic Tester, highlight each system with a “**NG**” and press enter to retrieve the codes. Record the DTCs and the related system below:

CODES

SYSTEM

12. After the codes are recorded, clear all the codes by entering each area individually.
13. Re-install the circuit opening relay and cycle the ignition key OFF and back to the READY position to re-start engine.
14. Using TIS, look up the **TSB** regarding **Maintenance for HV and Aux. Batteries at Port and Dealers**. Once you have opened the TSB, search for **Onboard Equalizing Charge of HV Battery**. Follow the instructions and begin the battery equalization process to re-charge the HV battery.

NOTE: This procedure is only for the '01-'03 Prius.

Notify the instructor when you are finished.



Notes



SELF-ASSESSMENT 4-1
Out of Gas Condition

Name:	Date:
-------	-------

Self-assessment Objectives

Review this sheet as you are doing the Out of Gas Condition worksheet. Check off either category after completing the worksheet and instructor presentation. Ask the instructor if you have questions. The **Comments** section is for you to write notes on where to find the information, questions, etc.

I have questions

I know I can

Topic			Comment
Create User Data from the Battery ECU Data List.			
Locate and remove the circuit-opening relay.			
Determine the SOC.			
Record DTCs.			



Notes



WORKSHEET 4-2
Inclination Sensor Reset

Vehicle	Year/Prod. Date	Engine	Transmission
---------	-----------------	--------	--------------

Worksheet Objectives

In this worksheet you will reset the Inclination Sensor. This procedure can be useful in solving a customer concern about improper fuel reading.

Tools and Equipment

- Vehicle
- Repair Manual

Section 1: Inclination Sensor Reset

Note: Be sure vehicle is on a level surface before resetting the Inclination Sensor.

1. Reset the Inclination Sensor when replacing a Combination Meter or responding to a customer concern about improper fuel reading or repeatedly running out of gas. Please refer to the BE section of the Repair Manual for complete reset procedures.
2. Answer the questions on the following page while doing the procedures below.
3. **On the '04 and later Prius:**
 - With the trip meter set to Trip A, depress and hold the Trip button while pressing the power button twice. (Do not put your foot on the brake.)
 - Push the trip switch two times within five seconds.
 - Push and hold the trip switch for five seconds or more then release.
 - Check that the inclination sensor information is displayed in the dash.
 - Push and hold the trip switch for five seconds or more to update the centered value.
 - When value is displayed for five seconds, the third digit will indicate the status. The value of 1 indicates a successful reset.
4. **On the '01-'03 Prius:**
 - Depress and hold the Trip button while turning the ignition key to the ON position.
 - Release and press the Trip button three more times within five seconds: Release-Press-Release-Press-Release-Press and Hold.

- Continue holding the Trip button for at least five seconds, then release.
- Check that the inclination sensor information is displayed in the dash.

(*) Current result display mode

- 0: Input state
- 1: Input state complete
- 2: E2ROM error
- 3: Speed input during input state or cancel during ODO input state

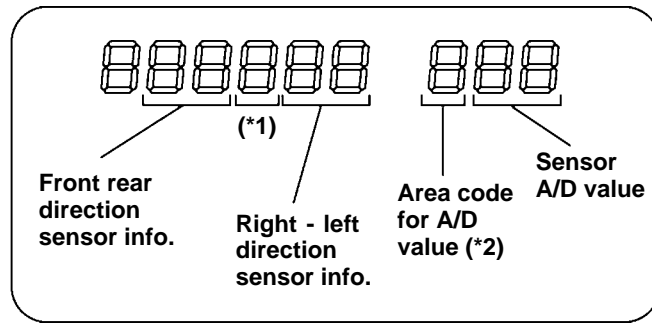

(*2)

- 0: Horizontal
- 1: 3° to 5°
- 2: Over 5°
- 3: Error

Note: This procedure may take several attempts. Each time you start again, remove the key from the ignition and wait at least five seconds.

5. List the six-digit number displayed.

6. What do the first three digits mean? What do the last three digits mean?

7. After recording the six-digit number, lean on the front or rear bumper. Are the numbers changing?

8. Release the bumper and allow the vehicle to return to normal ride height.

9. When you pressed and held the Trip button for at least five seconds at the end of the procedure a single number should have appeared. What number was displayed?

10. According to the repair manual, what does this number mean?

Result Display Mode

- 0: Under processing
- 1: Recording completed
- 2: EEPROM error
- 3: Speed input or cancel during setting

If the number one (1) appeared, you are finished and the sensor is now reset. This allows for proper fuel and gas mileage reading.



Notes



Notes

Section 5

Chassis

Overview Toyota hybrid vehicles use a number of specialized chassis systems including:

- A shift-by-wire system with electronic transmission control.
- A regenerative braking system that recovers much of the energy normally lost to heat and friction during braking.
- An Electric Power Steering (EPS) system that improves fuel economy because it only consumes energy when it is in use.

Shift Control ('01-'03 Prius) The '01-'03 Prius uses a shift-by-wire system. The shift position sensor is connected to a column-mounted shift lever and outputs two voltage signals: a main signal and a sub signal. Both contain information about shift position. The HV ECU determines shift position when both signals match.

Shift Control ('04 & later Prius) The '04 & later Prius uses a different shift-by-wire system. It uses two sensors to monitor shift lever movement: a Select Sensor that detects the lateral movement and a Shift Sensor that detects the longitudinal movement. The combination of these signals is used to determine shift position. When shift selection is complete, the reactive force of a spring returns the lever to its home position.

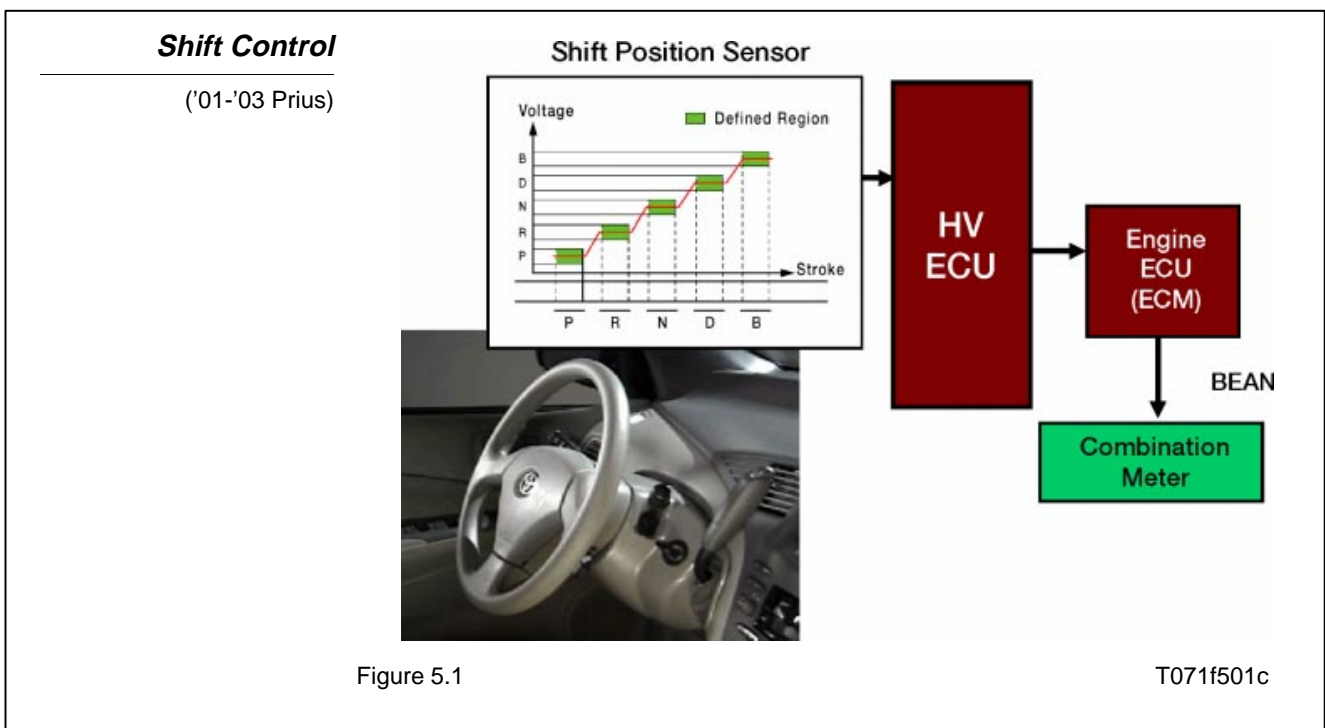

Shift Lock

('01-'03 Prius)

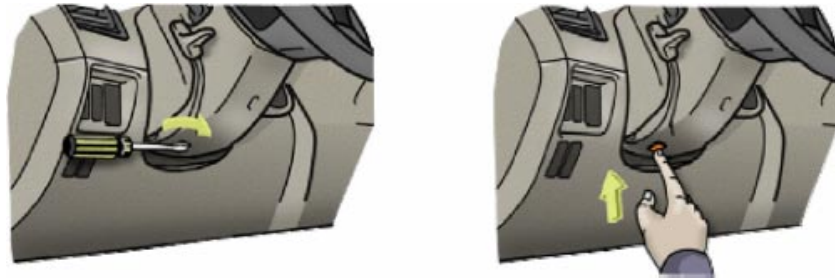

Figure 5.2

T071f502c

Shift Assembly

('04 & later Prius)

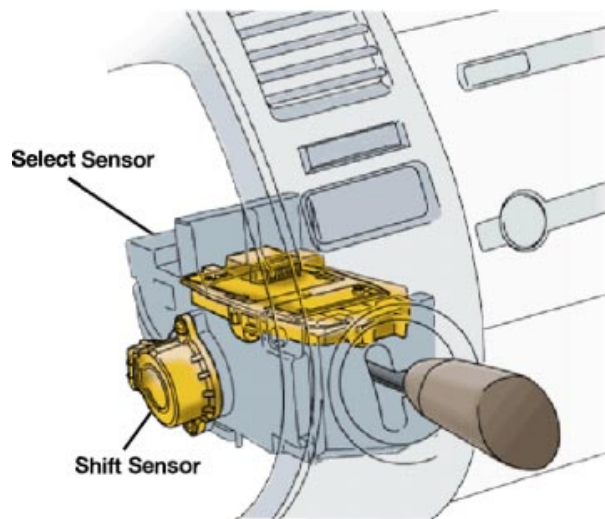
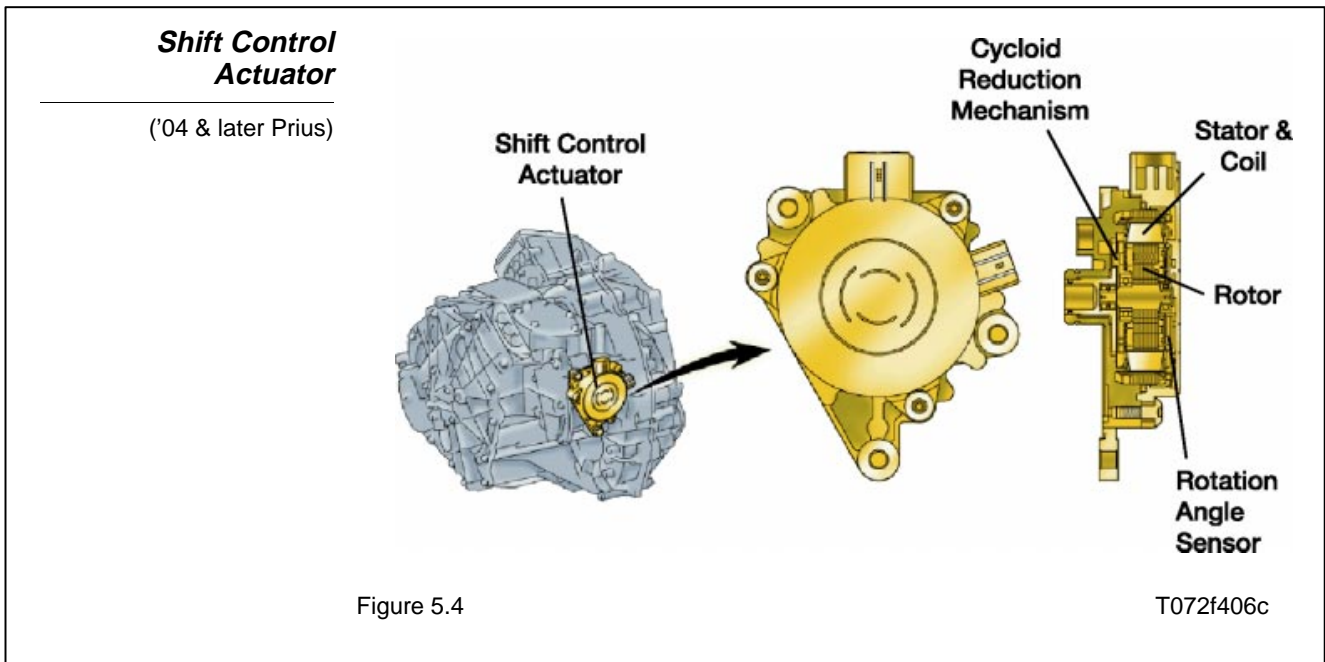

Figure 5.3

T072f107c

Shift Control Actuator ('04 & later Prius)

The '04 & later Prius uses an electronic Shift Control Actuator to engage the parking pawl. When the Shift Control Actuator receives a lock signal from the transmission ECU it rotates, which moves the parking lock rod and forces the parking lock pawl to engage the parking gear. The Shift Control Actuator detects its own position when the battery is reconnected, so it does not require initialization.

**SERVICE TIP**

If there is a malfunction in the shift control actuator, the vehicle will not go into park. The Master Warning Light will illuminate, the shift position indicators on the dash will flash, and the Park button light will flash.

In this case, the vehicle cannot be turned OFF unless the parking brake is applied. Then the vehicle can be turned OFF but cannot be turned back ON again.

Cycloid Reduction Mechanism
(’04 & later Prius)

The Shift Control Actuator includes a cycloid gear reduction mechanism that increases the actuator’s torque, ensuring that the parking lock will release when the vehicle is parked on a slope.

This mechanism consists of an eccentric plate mounted on the motor’s output shaft, a 61-tooth fixed gear that is secured to the motor housing and a 60-tooth driven gear. As the output shaft rotates, the eccentric plate presses the driven gear against the fixed gear. The driven gear, which has one tooth less than the fixed gear, rotates one tooth for every complete rotation of the eccentric plate. The result is a gear reduction ratio of 61:1, along with an equivalent increase in torque.

Cycloid Reduction Mechanism

1. Eccentric shaft rotates with motor shaft, pressing driven gear against fixed gear.
2. Driven gear rotates one tooth for every full rotation of the motor shaft.
3. Reduction Ratio: 61:1.

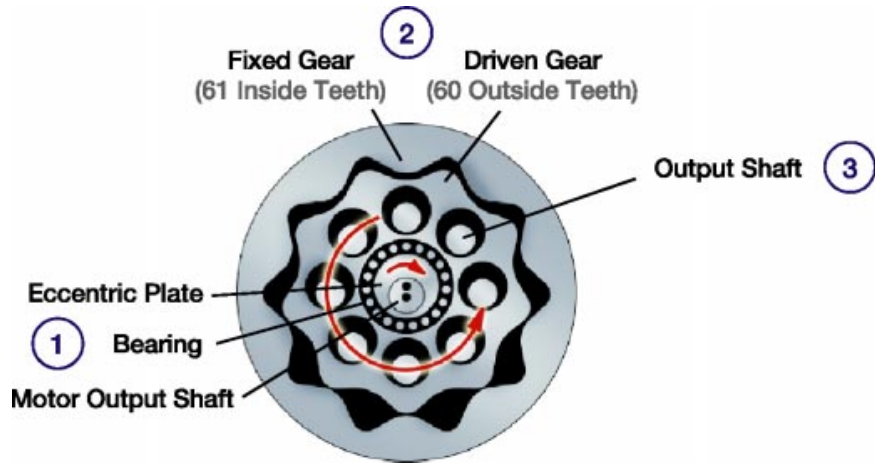

Figure 5.5

T071f505c

SERVICE TIP

The Diagnostic Tester cannot turn off the shift control system. To power down the system remove the 30-amp main fuse located on the left side of the fuse box on the driver's side of the engine compartment. This may be necessary if the vehicle needs to be pushed out of the shop.

Fuse Location

Removing the 30A PCON MTR fuse disables the shift control system.

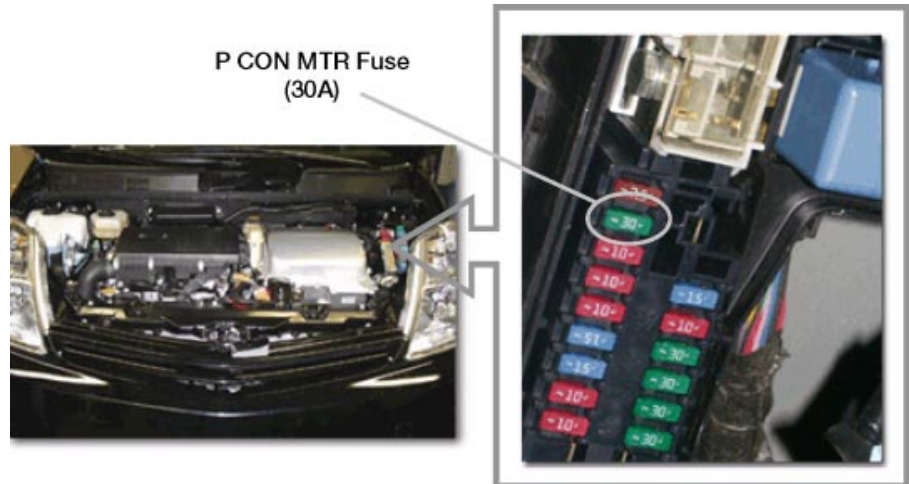

Figure 5.6

T071f506c

Brake System The hybrid vehicle brake system includes both hydraulic brakes and a unique regenerative braking system that uses the vehicle's momentum to recharge the HV battery. As soon as the accelerator pedal is released, the HV ECU initiates regenerative braking. MG2 is turned by the wheels and used as a generator to recharge the HV battery. During this phase of braking, the hydraulic brakes are not used. When more rapid deceleration is required, the hydraulic brakes are activated to provide additional stopping power.

To increase energy efficiency the system uses the regenerative brakes whenever possible. Selecting "B" on the shift lever will maximize regenerative efficiency and is useful for controlling speeds downhill. In 'B' mode, about 30% of the energy is recovered.

If either the regenerative or hydraulic braking system fails, the remaining system will still work. However, the brake pedal will be harder to press and the stopping distance will be longer. In this situation, the brake system warning light will illuminate.

NOTE

The battery will accept charge up to an instantaneous rate of 20 to 21 KWH. Much of the energy from light braking at high speeds and harder braking at lower speeds can be recovered. Excess energy over the charging limits is wasted as heat in the brakes. At this time there is no way for the driver to know the limit of regenerative energy recovery.

Brake System Components

('01-'03 Prius)

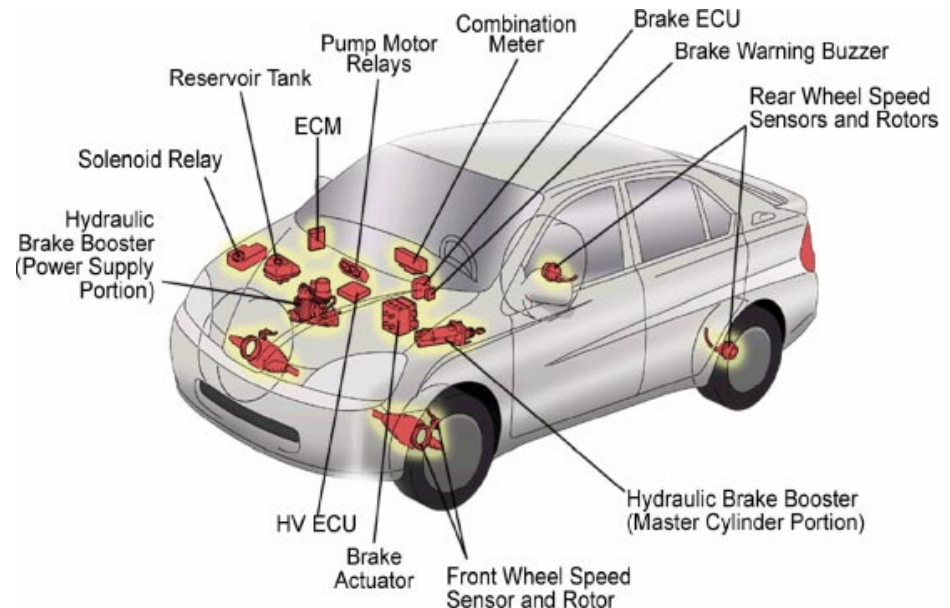
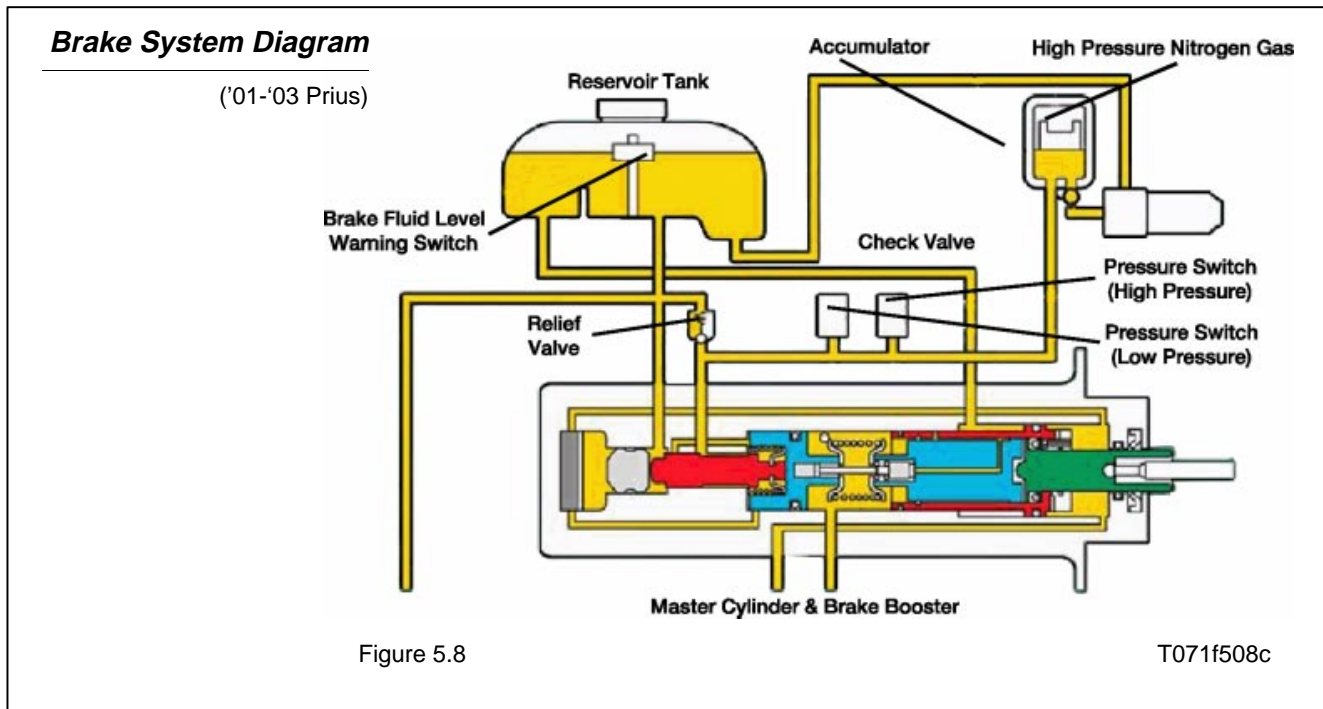

Figure 5.7

T071f507c



Hydraulic Brake Booster (’01-’03 Prius)

The ’01-’03 Prius applies hydraulic pressure from the master cylinder directly to the front brakes. For the rear brakes, it uses a hydraulic brake booster to increase brake force. Within the hydraulic brake booster, a pump draws brake fluid from the reservoir tank and forces it into the accumulator under high pressure. The accumulator stores the high-pressure fluid until it is needed.

To make sure system pressure stays at the right level, two pressure switches monitor hydraulic pressure coming from the accumulator:

- Pressure Switch PH - controls pump activation.
- Pressure Switch PL – generates a warning when system pressure is too low.

If one of the pressure switches malfunctions it can cause the pump to operate continuously, creating excessive pressure in the system. If that happens, a relief valve shunts brake fluid to the reservoir tank to relieve the excess pressure.

If the brake booster fails, the Brake System Warning Light and Buzzer will illuminate. Pressing the brake pedal repeatedly may turn ON the Brake System Warning Light and Buzzer briefly. If the brake booster is operating normally, the light and buzzer will turn OFF after a few seconds after start up.

Brake Actuator ('04 & later Prius) In the '04 & later Prius, the conventional brake booster has been replaced by a hydraulic power source that is controlled by the Skid Control ECU.

The hydraulic power source uses many of the same components used on the previous system, including a pump, pump motor, accumulator, relief valve, 2 motor relays, and an accumulator pressure sensor. To improve the system, the accumulator has been made more gas-tight, and a plunger-type pump has been adopted.

The control portion of the brake actuator includes:

- 2 master cylinder solenoid valves
- 4 pressure appliance valves
- 4 pressure reduction valves
- 2 master cylinder pressure sensors
- 4 wheel cylinder pressure sensors

Brake ECU ('01-'03 Prius) In the '01-'03 Prius, the Brake ECU controls the following brake functions:

- Conventional brake control
- ABS with EBD control
- Regenerative brake cooperative control

The Brake ECU exchanges sensor information with the HV ECU.

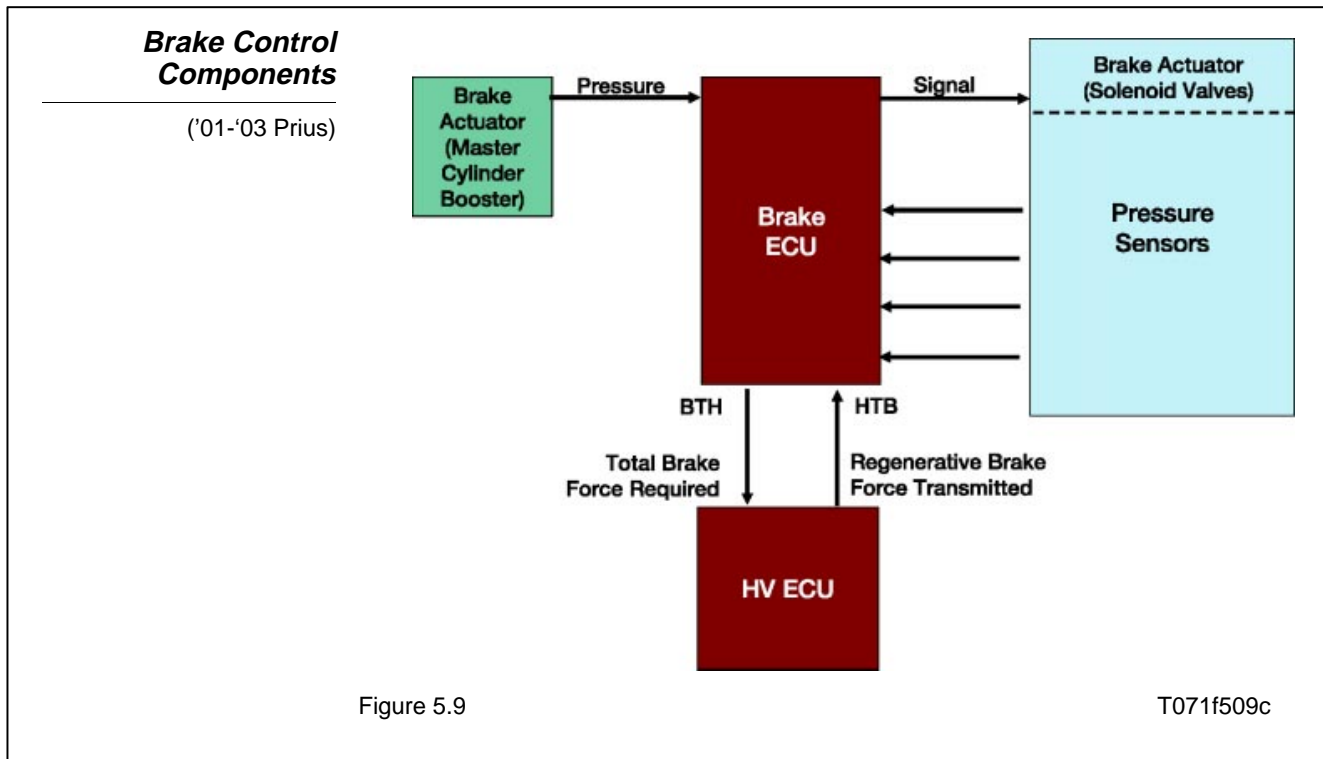

Skid Control ECU (’04 & later Prius) In the ’04 & later Prius, brake control processing is moved to the Skid Control ECU, which handles:

- Conventional brake control
- ABS with EBD control
- Brake Assist
- Enhanced VSC
- Regenerative brake cooperative control

The Skid Control ECU exchanges sensor information EPS ECU and the HV ECU.

Brake Pedal Stroke Sensor

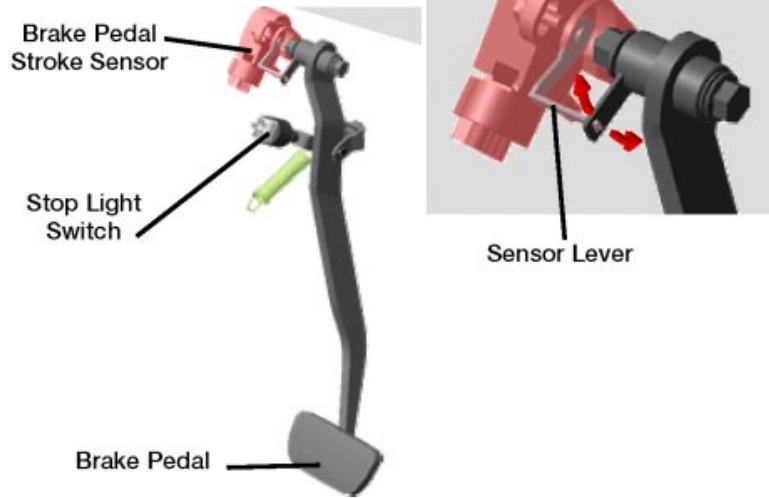
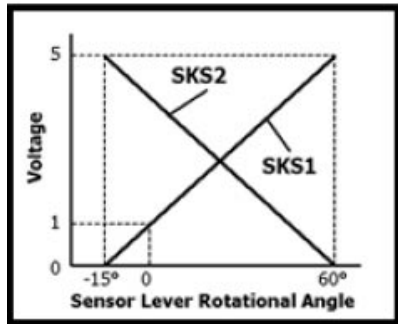

Figure 5.11

T071f511c

Stroke Simulator During regenerative braking fluid flow to the front calipers is limited. To retain a normal pedal stroke during regenerative braking, the Stroke Simulator consumes some of the fluid flow from the master cylinder so that the pedal can move normally.

The stroke simulator is located between the master cylinder and the brake actuator. It uses two coil springs with different spring constants to provide pedal stroke characteristics in two stages.

Stroke Simulator

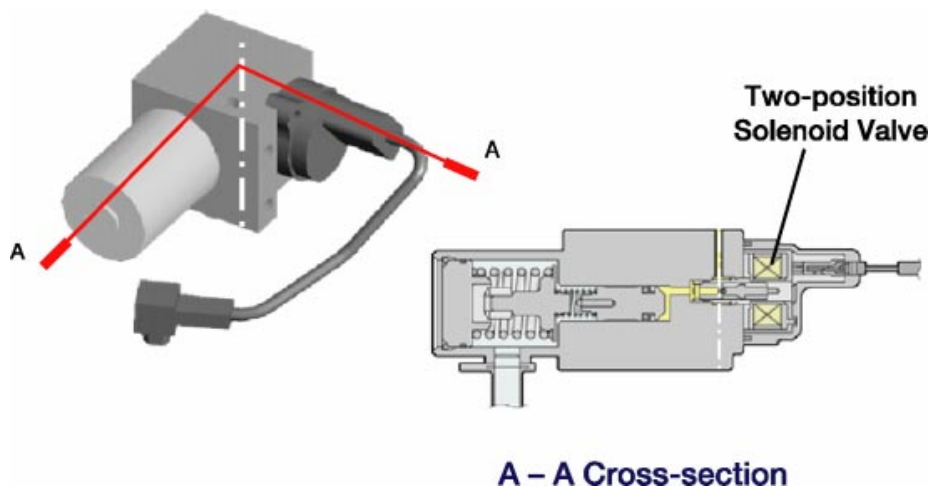

Figure 5.12

T072f112c

Power Source Backup Unit ('04 & later Prius)

In the '04 & later Prius a Power Source Backup Unit has been added so that the ECB will function long enough to stop the vehicle even if the 12V battery is compromised. The unit contains 28 capacitor cells that store an electrical charge provided by the vehicle's 12V power supply. The capacitor cells discharge when the power switch is turned OFF.

If the Power Source Backup Unit is removed, it must first be checked for residual voltage.

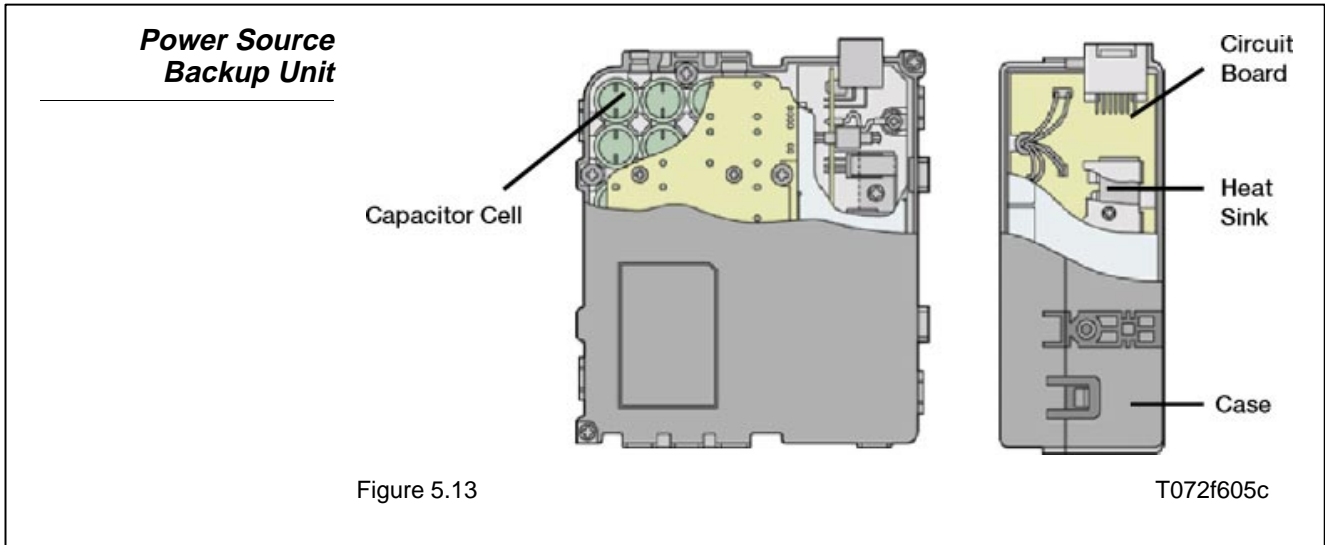

Regenerative Brake Cooperative Control

Regenerative brake cooperative control balances the brake force of the regenerative and hydraulic brakes to minimize the amount of kinetic energy lost to heat and friction. It recovers the energy by converting it into electrical energy.

On the '04 & later Prius, the increased power output of MG2 provides increased regenerative brake force. In addition, the distribution of the brake force has been improved through the adoption of the ECB system, effectively increasing the range of the regenerative brake. These attributes enhance the system's ability to recover electrical energy which contributes to fuel economy.

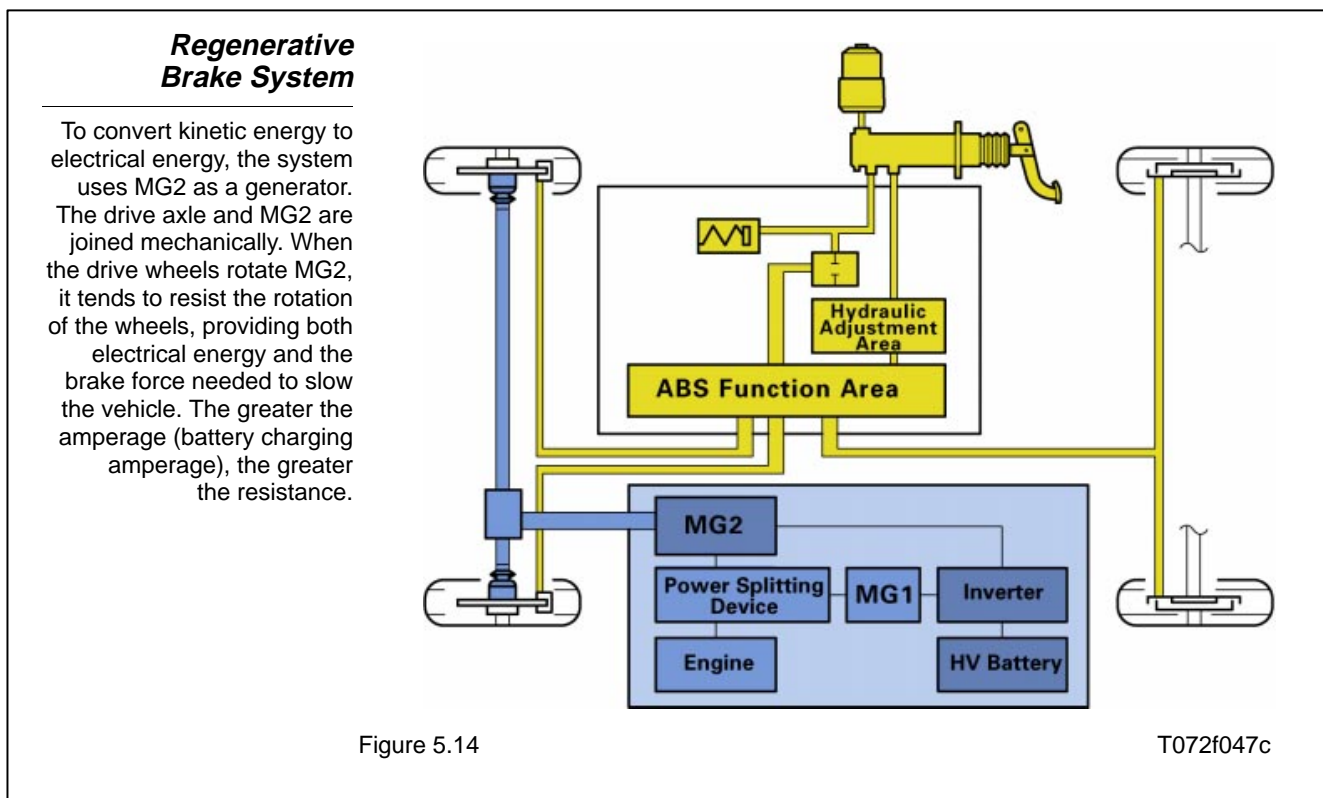

**Electronic Brake
Distribution (EBD)
Control
(’04 & later Prius)**

In the ’04 & later Prius, brake force distribution (which was performed mechanically in the past) is now performed under electrical control of the skid control ECU. The skid control ECU precisely controls the braking force in accordance with the vehicle’s driving conditions.

**Brake Force
Distribution -
Front/Rear
(’04 & later Prius)**

Generally, when the brakes are applied the vehicle’s weight shifts forward, reducing the load on the rear wheels. When the Skid Control ECU senses this condition (based on speed sensor output) it signals the brake actuator to regulate rear brake force so that the vehicle will remain under control during the stop. The amount of brake force applied to the rear wheels varies based the amount of deceleration. The amount of brake force that is applied to the rear wheels also varies based on whether or not the vehicle is carrying a load.

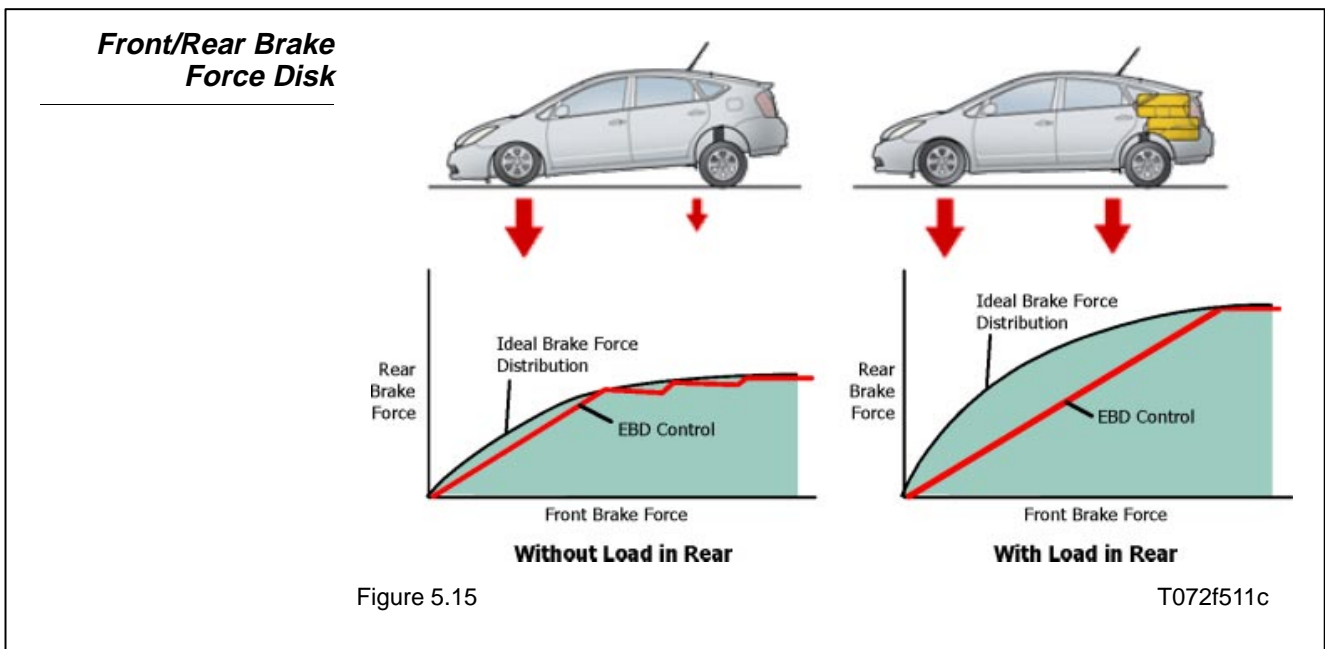

**Brake Force
Distribution -
Left/Right
(’04 & later Prius)**

When the brakes are applied while the vehicle is cornering, the load applied to the inner wheel decreases while the load applied to the outer wheel increases. When the Skid Control ECU senses this condition (based on speed sensor output) it signals the brake actuator to regulate brake force between the left and right wheels to prevent a skid.

Brake Assist System (’04 & later Prius)

In emergencies, drivers often panic and do not apply sufficient pressure to the brake pedal. So on the ’04 & later Prius, the Brake Assist system interprets a quick push of the brake pedal as emergency braking and supplements braking power accordingly.

To determine the need for an emergency stop, the Skid Control ECU looks at the speed and the amount of brake pedal application based on signals from the master cylinder pressure sensors and the brake pedal stroke sensor. If the Skid Control ECU determines that the driver is attempting an emergency stop it signals the brake actuator to increase hydraulic pressure.

A key feature of the Brake Assist system is that the timing and the degree of braking assistance are designed to ensure that the driver does not discern anything unusual about the braking operation. As soon as the driver eases up on the brake pedal, the system reduces the amount of assistance it provides.

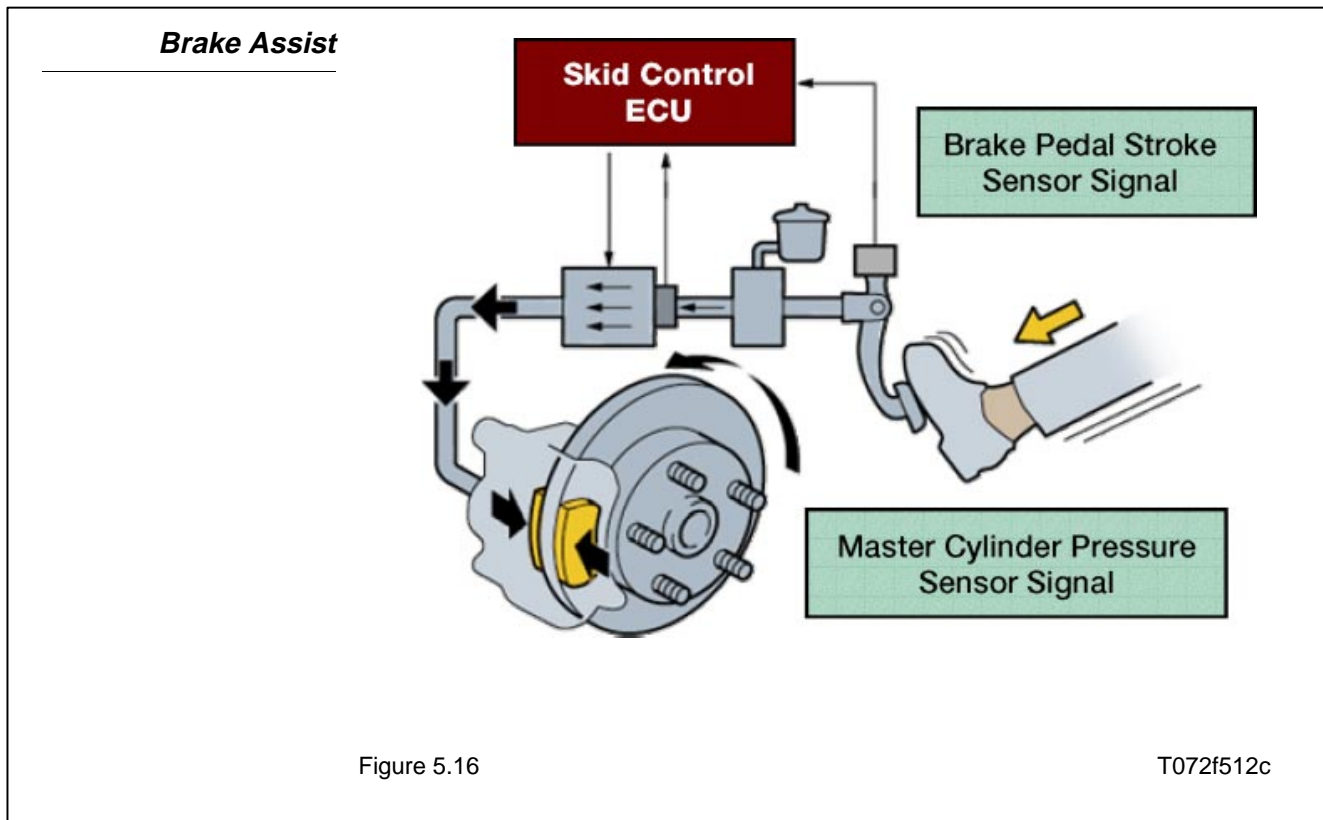

Enhanced VSC System ('04 & later Prius)

The Enhanced VSC system available on the '04 & later Prius helps maintain stability when the vehicle's tires exceed their lateral grip. The system helps control the vehicle by adjusting the motive force and the brakes at each wheel when:

- The front wheels lose traction but the rear wheels don't. (front wheel skid tendency known as 'understeer')
- The rear wheels lose traction but the front wheels don't. (rear wheel skid tendency, or 'oversteer')

When the Skid Control ECU determines that the vehicle is in understeer or oversteer, it decreases engine output and applies the brakes to the appropriate wheels individually to control the vehicle.

- When the skid control ECU senses understeer, it brakes the front and rear inside wheel. This slows the vehicle, shifts the load to the outside front wheel and limits front wheel skid.
- When the skid control ECU senses oversteer, it brakes the front and rear outside wheel. This restrains the skid and moves the vehicle back toward its intended path.

Cooperative Control with EPS ('04 & later Prius)

Enhanced VSC provides the appropriate amount of steering assist based on driving conditions by coordinating EPS and VSC control.

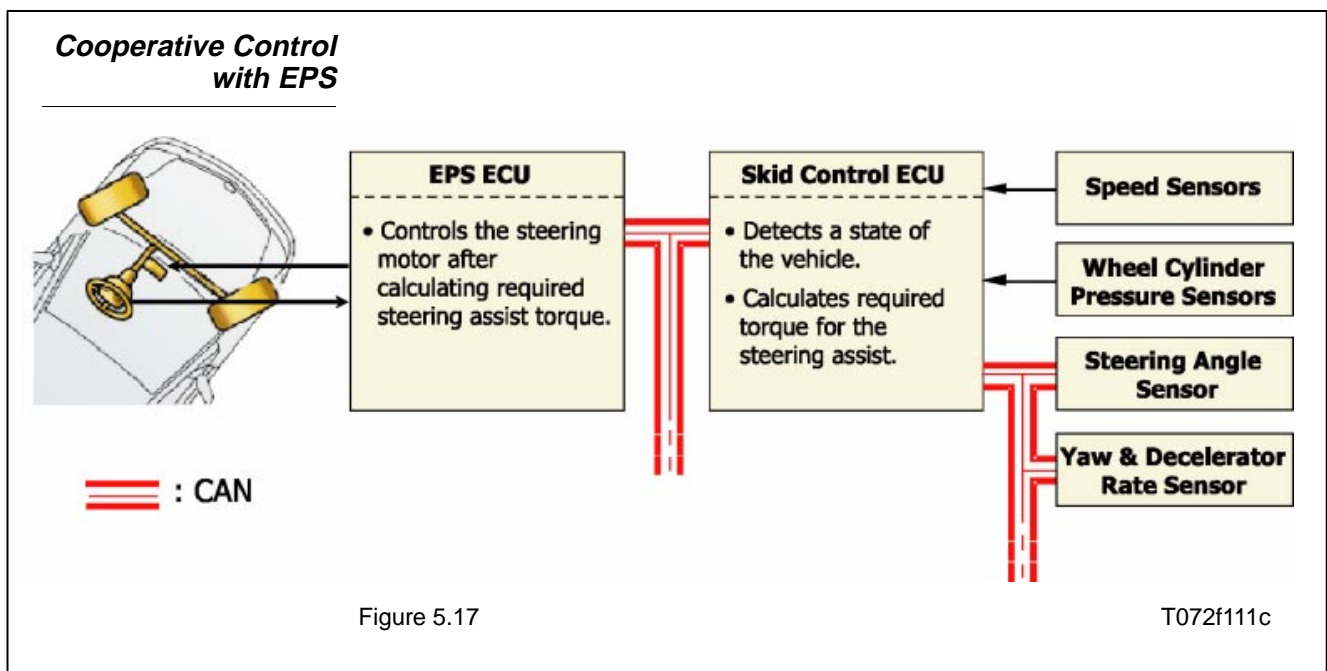

Electric Power Steering

A 12V motor powers the EPS system so that steering feel is not affected when the engine shuts off. The EPS ECU uses torque sensor output along with information from the Skid Control ECU about vehicle speed and torque assist demand to determine the direction and force of the power assist. It then actuates the DC motor accordingly.

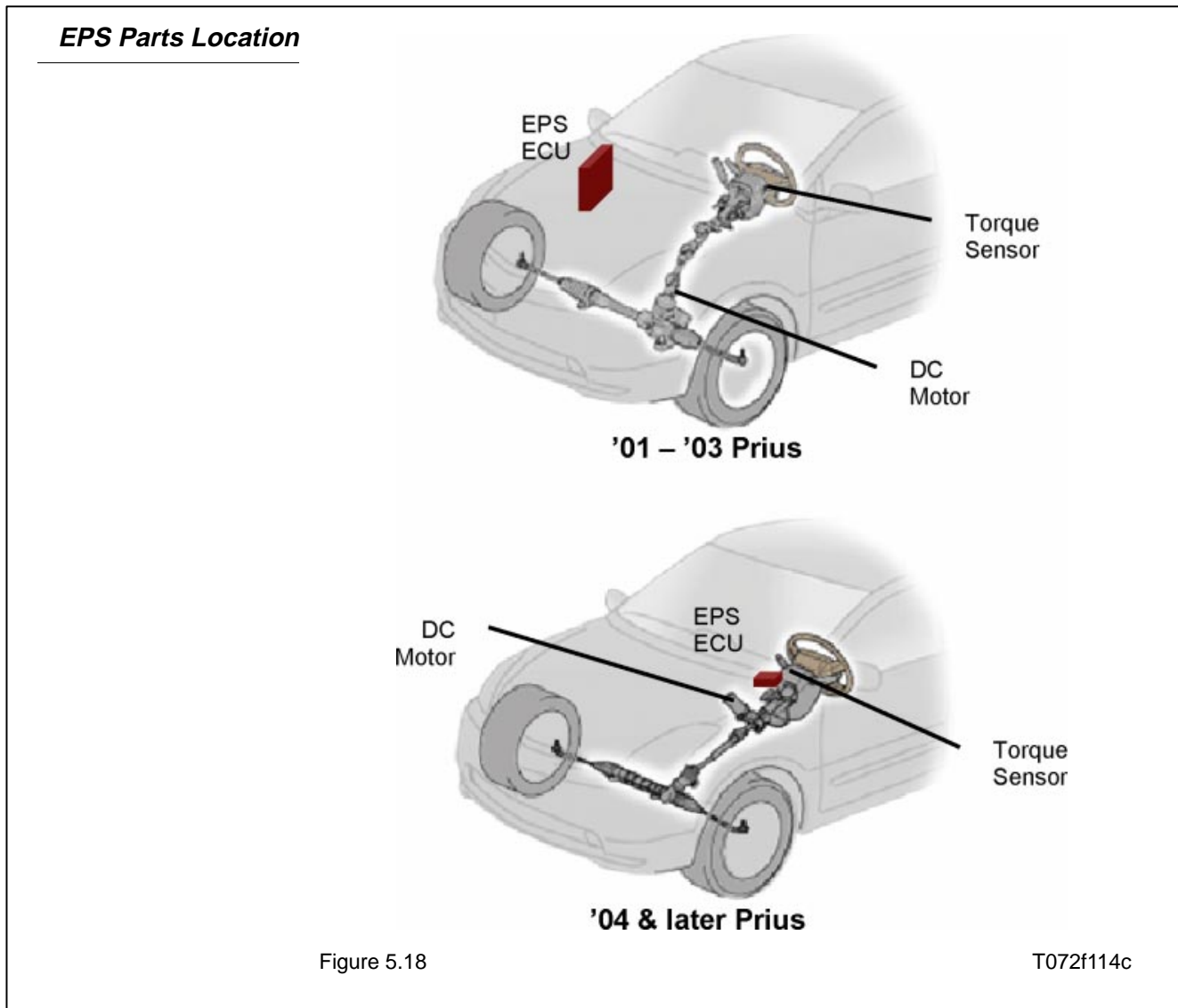

EPS ECU The EPS ECU uses signals from the torque sensor to interpret the driver's steering intentions. It combines this information with data from other sensors regarding current vehicle conditions to determine the amount of steering assist that will be required. It can then control the current to the DC motor that provides steering assist current to the DC motor that provides steering assist.

EPS Steering System

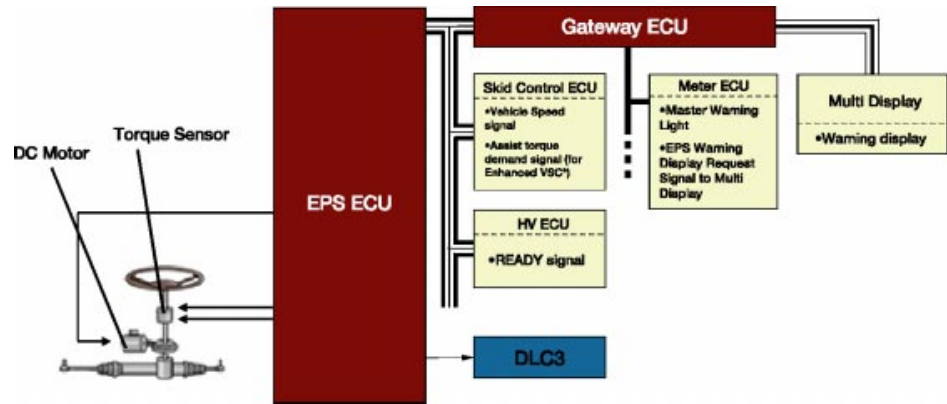

Figure 5.19

T072f049c

Power Steering System

When the steering wheel is turned, torque is transmitted to the pinion causing the input shaft to rotate. The torsion bar that links the input shaft and the pinion twists until the torque and the reaction force equalize. The torque sensor detects the twist of the torsion bar and generates an electrical signal that is proportional to the amount of torque applied to the torsion bar. The EPS ECU uses that signal to calculate the amount of power assist the DC motor should provide.

The '01-'03 Prius torque sensor is a surface-contact resistor and the '04 & later Prius uses an induction-type torque sensor.

DC Motor

The DC motor uses a worm gear to transmit the motor's torque to the column shaft.

Torque Sensor

('01-'03 Prius)



Figure 5.20

T071f520p

Torque Sensor

('04 & later Prius)

Detection Ring 1 and 2 are mounted on the input shaft and Detection Ring 3 is mounted on the output shaft. When torque is applied to the torsion bar the detection rings move in relationship to each other. The detection coil senses a change in inductance that is proportional to the amount of torque applied.

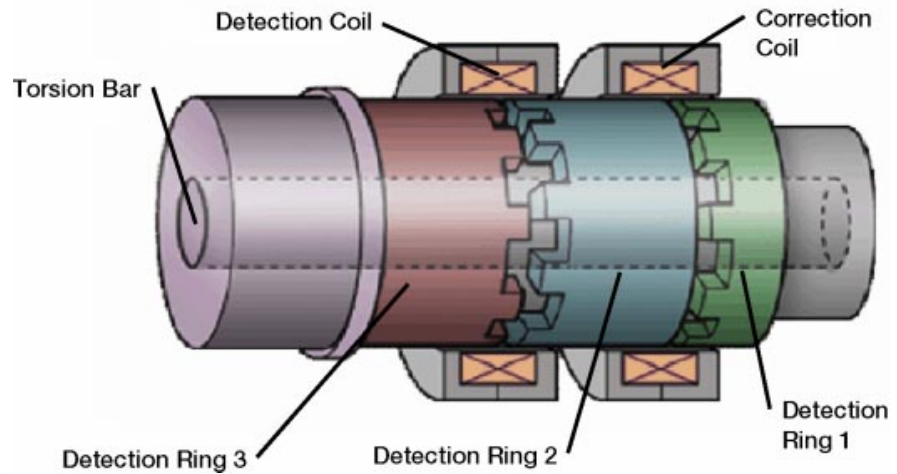

Figure 5.21

T072f049c

Reduction Mechanism ('01-'03 Prius)

For '01 to '03, the reduction mechanism transmits power assist from the motor to the pinion shaft. The reduction mechanism consists of a pinion gear integrated with the motor shaft and a ring gear that is secured to the pinion shaft.

Reduction Mechanism ('04 & later Prius)

For '04 & later, the reduction mechanism transmits power assist from the motor to the column shaft. The reduction mechanism consists of a worm gear integrated with the motor shaft and wheel gear that is connected to the column shaft.

Fail Safe If the EPS ECU detects a malfunction in the EPS system, a warning light illuminates to alert the driver. The EPS ECU will store the DTC(s) and the system will power down, however the system still provides the ability to steer manually.

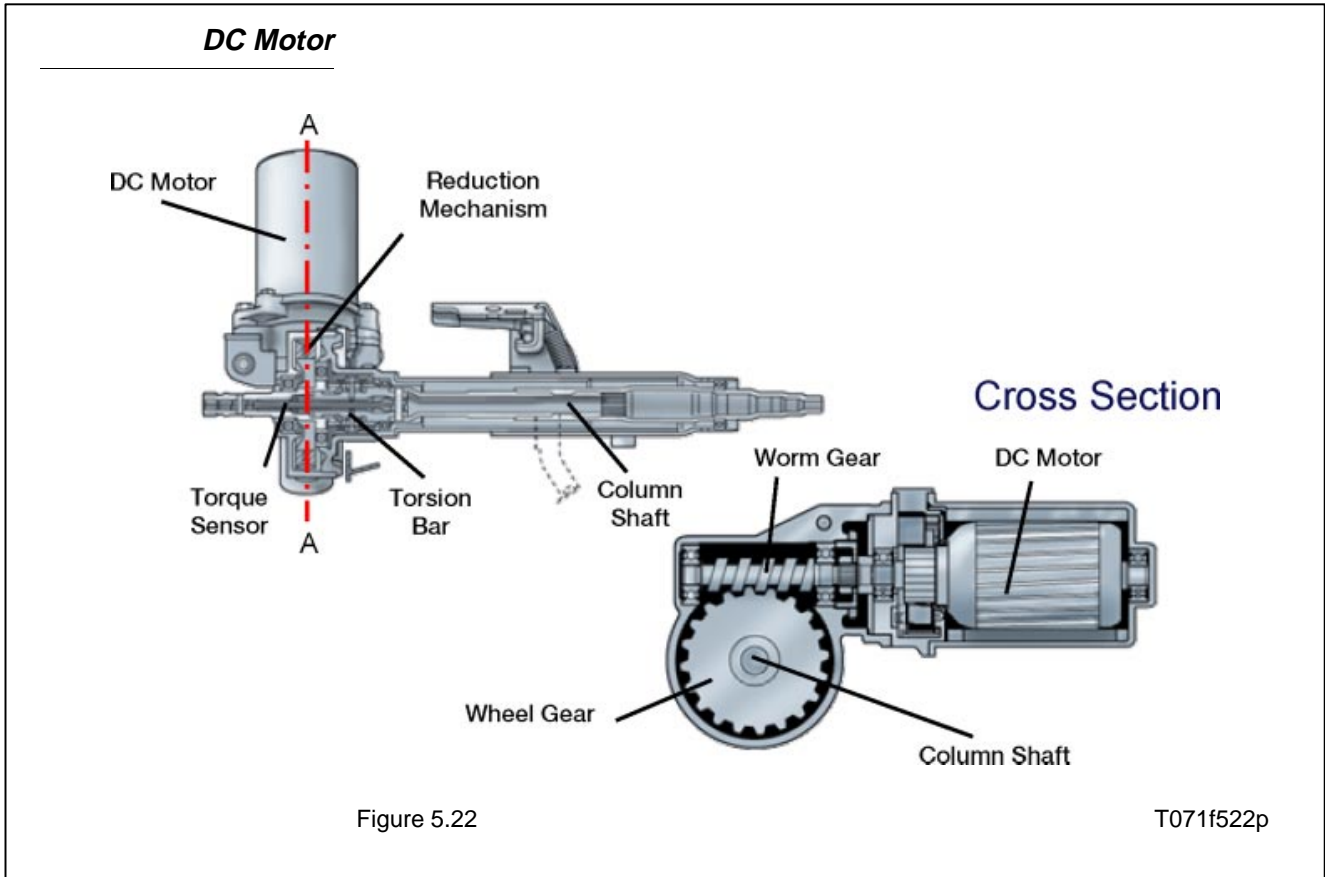



Notes

Section 6

Body Electrical

Overview The body electrical system includes special technology to increase fuel efficiency and accommodate the special requirements of a hybrid powertrain. For instance, the 2004 & later Prius uses an electric compressor so that A/C operation is not dependent on the engine. It also uses a humidity sensor to make cabin dehumidification more efficient.

To maintain communication between the vehicle's many electronic control components, hybrid vehicles use three types of multiplex communication: CAN, BEAN and AVC-LAN. A Gateway ECU is used to link the three circuits.

Air Conditioning System The Prius A/C unit provides 2-way flow so it can recirculate warm internal air in the foot well while simultaneously introducing fresh, dry external air to the upper part of the cabin. This allows it to effectively heat the vehicle and demist the windshield at the same time.

- The '01-'03 Prius air conditioning is controlled from the air conditioning control panel.
- The '04 & later Prius air conditioning system can be controlled either from the air conditioning screen on the multi display or from switches on the steering pad.

The system includes several components to meet the special requirements of a hybrid vehicle.

- The '04 & later Prius includes an electric compressor that is powered by the inverter and does not draw any power unless it is needed to run the A/C.
- The hybrid vehicle A/C system also uses two Positive Temperature Coefficient (PTC) heaters embedded in the heater core to supplement the heat provided by the engine.

The A/C control circuits include special logic tailored to support the hybrid powertrain. If the HV battery becomes too warm with recirculation ON, the HV battery ECU will switch to FRESH in order to increase the flow of air across the battery.

A/C Main Components

(*04 later Prius)

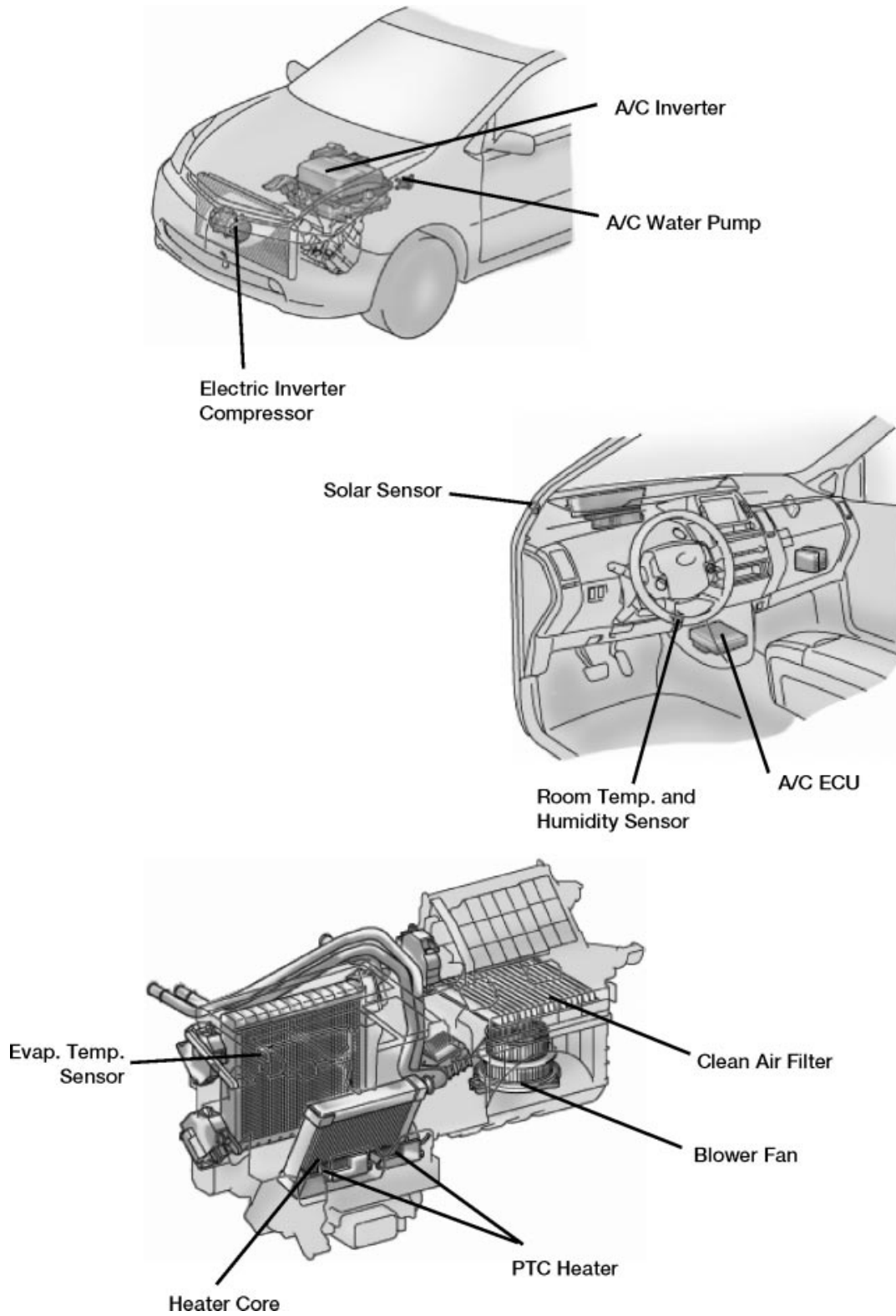
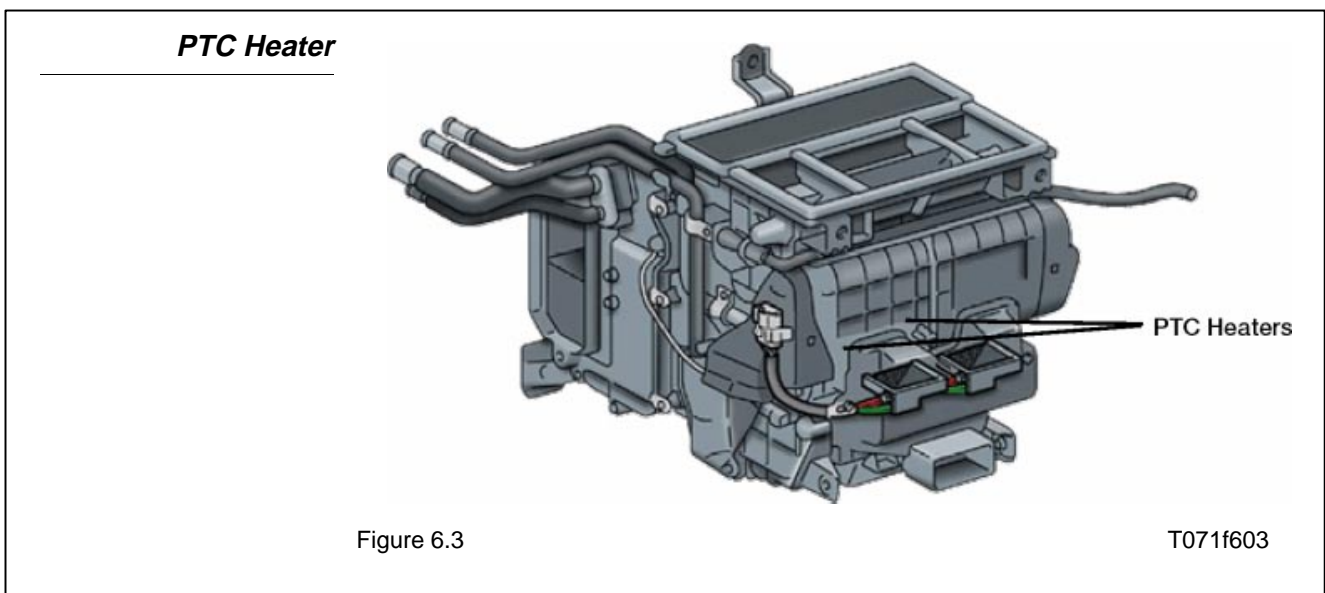
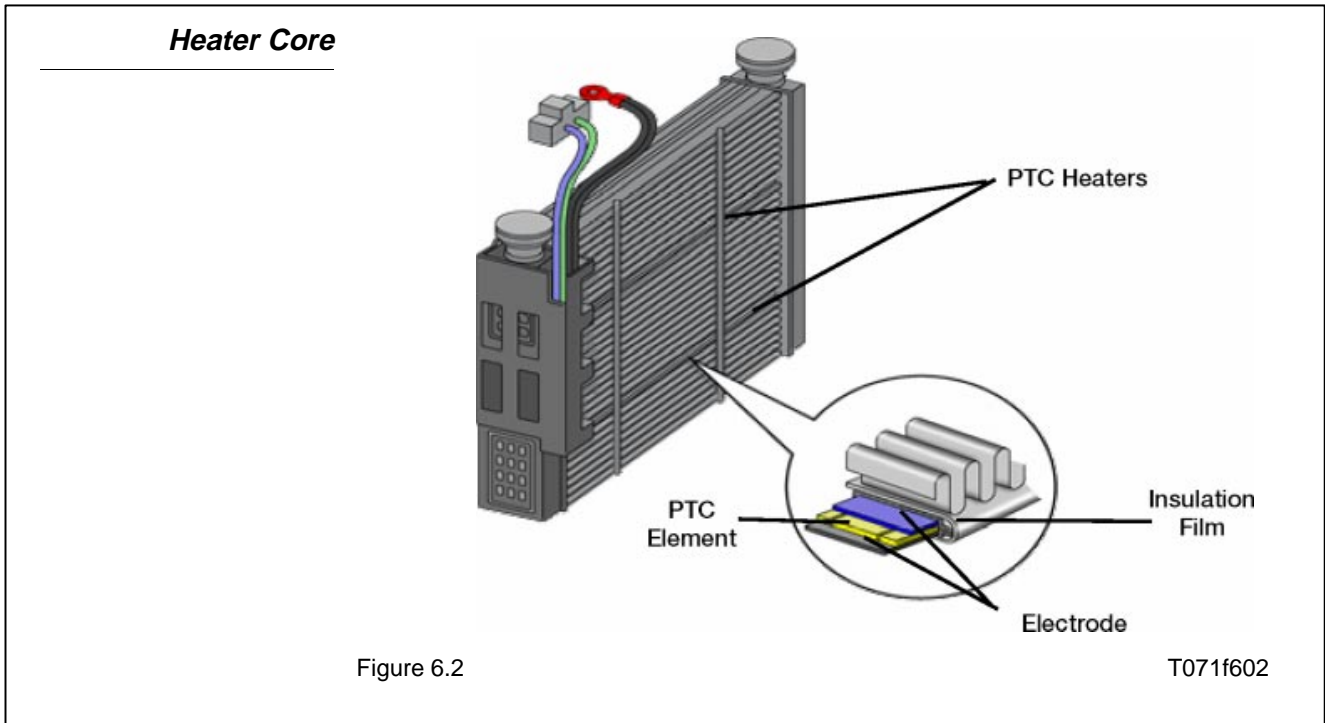

Figure 6.1

T071f601c

Heater Core and PTC Heater

The hybrid vehicle's gasoline engine is small, thermally efficient, and runs only when needed. Therefore, engine coolant may not always be hot enough to heat the cabin to a comfortable temperature. To address this, two 165-Watt PTC heater elements are embedded in the heater core and used to supplement engine heat when warming the vehicle.



Condenser and Sub-Cool Cycle

The Prius A/C condenser includes a sub-cooler that improves heat exchange efficiency. After the refrigerant passes through the condensing portion of the condenser, both the liquid refrigerant and any gaseous refrigerant that was not liquefied during condensation are cooled again in the super-cooling portion of the condenser. Because of this two-step approach the refrigerant sent to the evaporator is almost completely liquefied.

NOTE

When recharging most cooling systems, air bubbles disappear from the refrigerant when the system is full. With this system, however, air bubbles will disappear from the refrigerant *before* the system is full. See the Prius Repair Manual for the proper method of recharging this system.

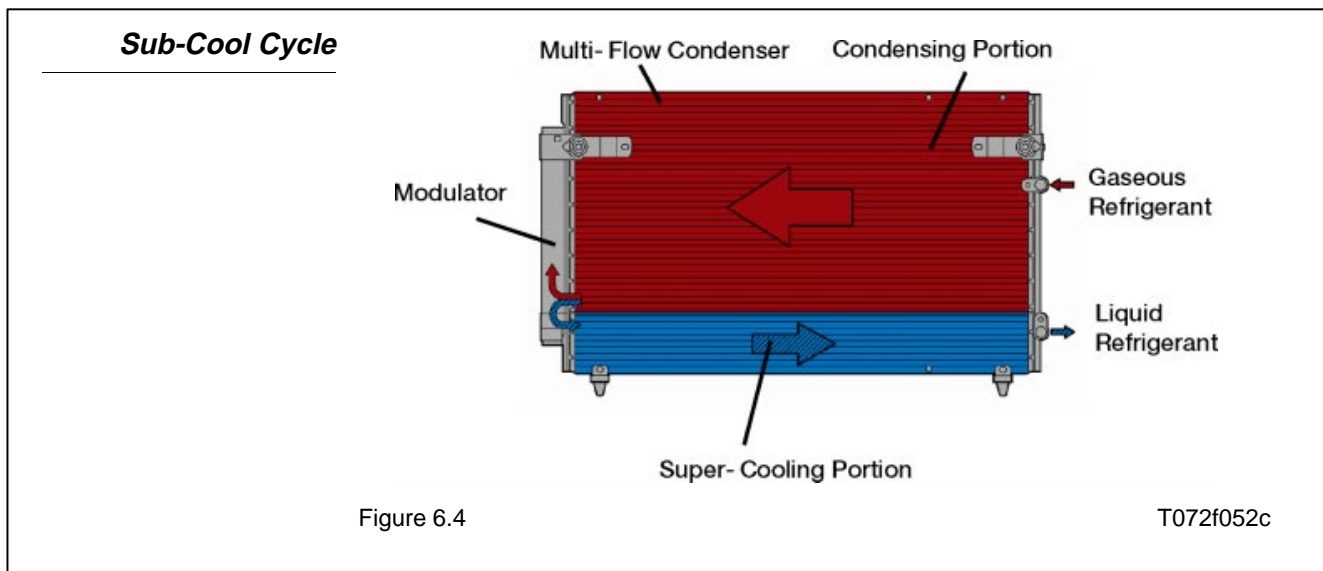

Compressor ('01-'03 Prius)

The '01-'03 Prius uses a scroll compressor with an oil separator that reduces the circulation of compressor oil in the system.

NOTE

When diagnosing the A/C, you may need to force the A/C system to remain on. Setting the controls to the MAX A/C position will cause the engine to remain on, maintaining A/C compressor operation.

A/C Compressor

Selecting MAX A/C on the '01-'03 Prius will cause the engine to run continuously



Figure 6.5

T071f605p

Electric Compressor ('04 & later Prius)

The '04 & later Prius uses an electric compressor driven by an integrated motor. The motor runs on 201.6V AC supplied by the A/C inverter so compressor operation does not depend on the engine.

The electric compressor consists of a spirally wound fixed scroll and variable scroll, a brushless motor, and an oil separator. The oil separator reclaims most of the compressor oil that is intermixed with the refrigerant. To insure proper insulation between the compressor housing and the high-voltage components inside the compressor, the '04 Prius uses a special high insulation value ND11 compressor oil. **NEVER** use any compressor oil other than ND11.

NOTE

The A/C compressor is powered by 201.6V AC. So when servicing the A/C compressor you should use the same high voltage safety procedures you would use for the vehicles other high voltage circuits.

Electric A/C Compressor

('04 & later Prius)



Figure 6.6

T071f606p

Room Temperature Sensor and Humidity Sensor ('04 & later Prius)

The room temperature sensor includes a humidity sensor to help make the A/C system's dehumidification process more effective. As a result, compressor power consumption has been reduced while still maintaining a comfortable humidity level within the cabin.

The humidity-sensing resistance film contains small carbon particles. As humidity in the cabin changes the hydroscopic film expands and contracts, changing the distance between the carbon particles. This changes the resistance of the film and sensor output voltage.

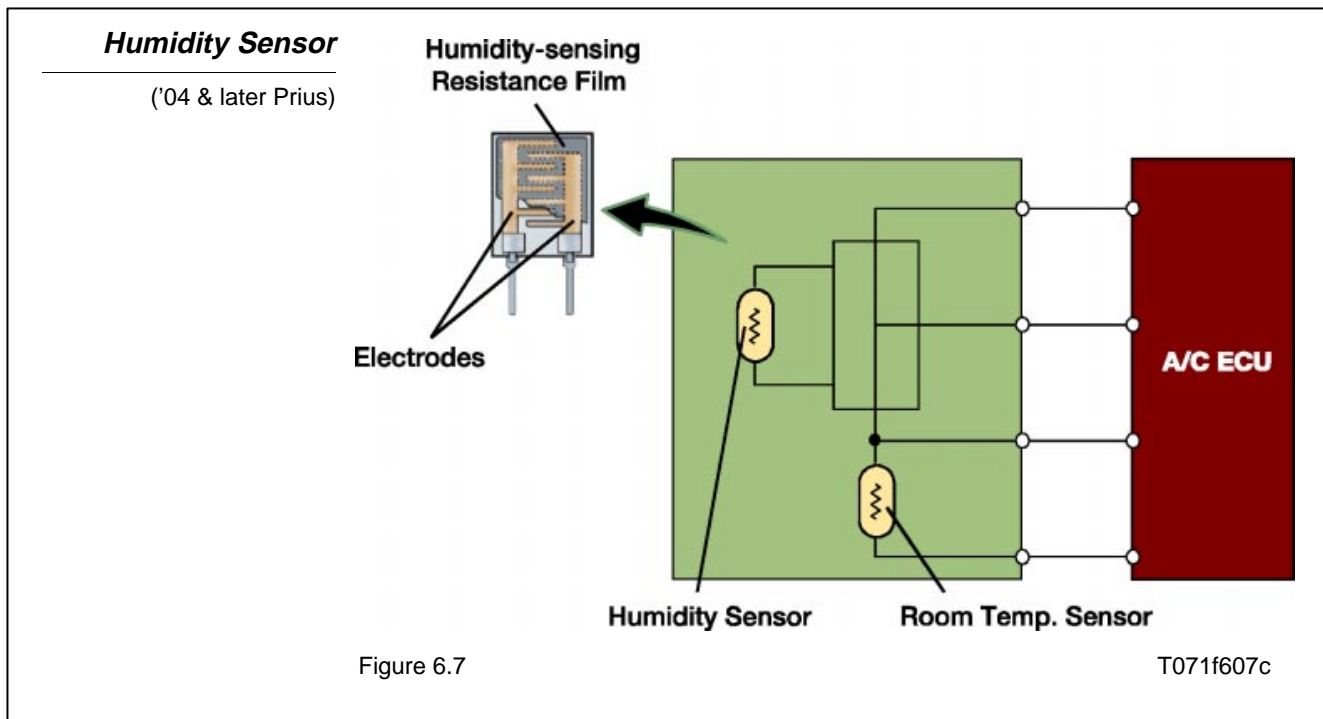

Water Pump The electric water pump provides stable heater performance even when the engine is stopped. When the engine is running the engine's water pump is forcing coolant through the system so the electric water pump does not operate.

On the '01-'03 Prius, when the engine's water pump is operating a bypass valve opens to minimize flow resistance. The bypass valve has been discontinued on the '04 & later Prius because a new pump design minimizes water flow resistance.

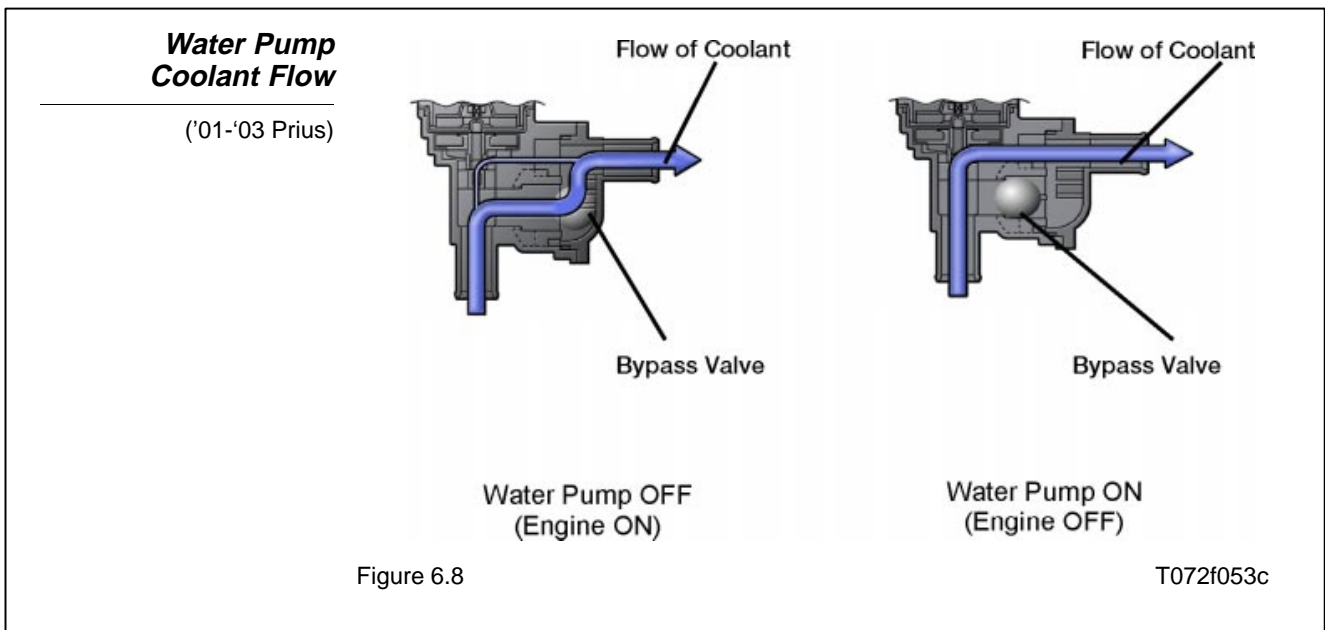

Multiplex Communication System

The Prius uses the following communication systems to coordinate vehicle activities:

- The Controller Area Network (CAN) links vehicle control systems that require high-speed communication, such as the ECM, HV ECU, Skid Control ECU and others.
- The Body Electronics Area Network (BEAN) connects the body control systems.
- The Audio Visual Communication – Local Area Network (AVC-LAN) links the audiovisual system ECUs and devices.

The Gateway ECU contains communication circuits that allow the CAN, BEAN and AVC-LAN systems to connect with each other.

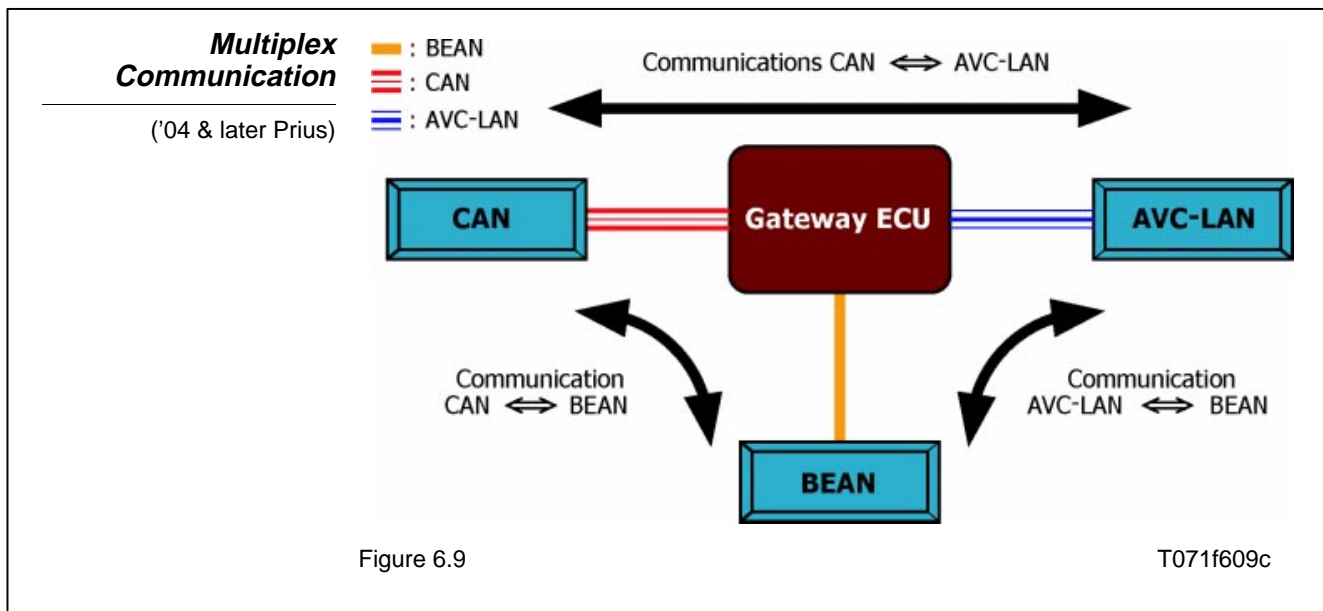

CAN System Diagram

CAN communication speed is 500 k bps ('04 & later Prius)

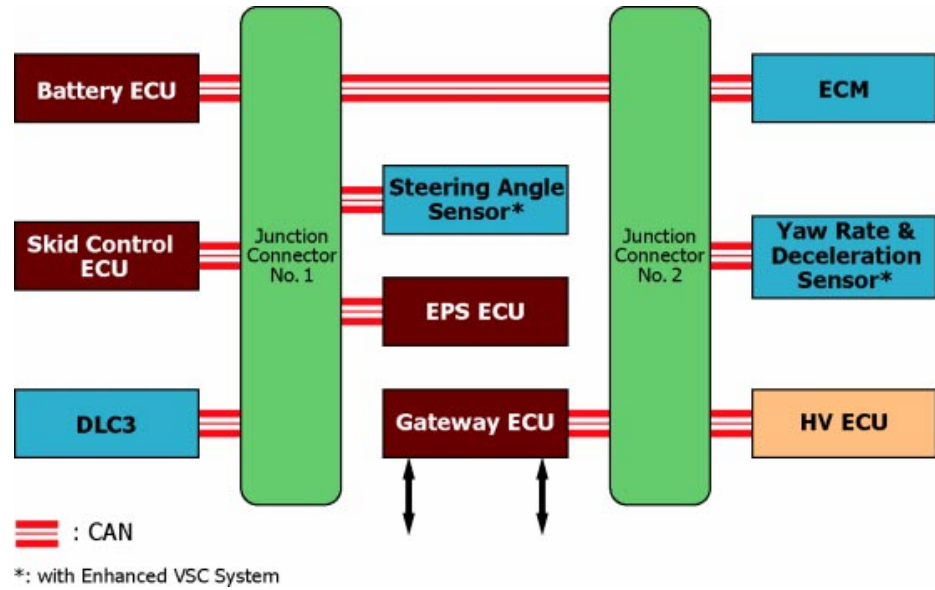

Figure 6.10

T071f610c

CAN, BEAN & AVC-LAN Chart

('04 & later Prius)

Control	Chassis Electrical System Control		Body Electrical System Control	
	CAN (ISO Standard)	BEAN (TOYOTA Original)	AVC-LAN (TOYOTA Original)	
Protocol	CAN (ISO Standard)	BEAN (TOYOTA Original)	AVC-LAN (TOYOTA Original)	
Communication Speed	500 k bps (Max. 1 M bps)	Max. 10 k bps	Max. 17.8 k bps	
Communication Wire	Twisted-pair Wire	AV Single Wire	Twisted-pair Wire	
Drive Type	Differential Voltage Drive	Single Wire Voltage Drive	Differential Voltage Drive	
Data Length	1-8 Byte (Variable)	1-11 Byte (Variable)	0-32 Byte (Variable)	

Figure 6.11

T071f611

Warranty The SULEV 2001-2003 Prius warranty offers:

- Basic - 3 years / 36,000 miles
- Powertrain (Engine, Transaxle with motors) - 5 years / 60,000 miles
- Hybrid System (HV Battery, HV Battery ECU, Hybrid ECU, Inverter and Converter) – 8 years / 100,000 miles

The AT-PZEV 2004 & later Prius, the warranty offers:

- Basic - 3 years / 36,000 miles
- Powertrain (Engine, Transaxle with motors) - 5 years / 60,000 miles
- Hybrid System – 8 years / 100,000 miles
- Emission Performance, Emission Defects, and Hybrid Battery Pack – 150,000 miles



WORKSHEET 6-1
Electric Air Conditioning System

Vehicle	Year/Prod. Date	Engine	Transmission
---------	-----------------	--------	--------------

Worksheet Objectives

This worksheet will familiarize you with the operation of the high voltage A/C compressor on the 2004 and later Prius using Active Tests and viewing the high and low pressures. You will also become familiar with the customize modes on the Diagnostic Tester, which allow A/C functions to be modified to suit customer needs.

Tools and Equipment

- Vehicle
- Pressure Gauges
- Diagnostic Tester
- Repair Manual
- New Car Features

Section 1: A/C Compressor

1. Describe the A/C compressor. What drives the compressor? What type of compressor is it?

2. What type of compressor oil is used and why is it unique to this system?

3. List the safety precautions that should be followed when servicing the A/C System.

Section 2: Refrigerant Pressure

1. Turn the A/C OFF and then turn the vehicle OFF.
2. Connect the pressure gauges to the high and low-pressure service ports.
3. Restart the vehicle, verifying it is in READY mode.
4. Connect the Diagnostic Tester to DLC3.
5. Select Active Test and COMPRS TARG SPD. Start at zero and note the refrigerant pressure. Increase the RPM to 4000 and note the pressure. Increase the RPM to 6000 and note the pressure.

Compressor Speed:	Low Side Pressure:	High Side Pressure:
Compressor Speed:	Low Side Pressure:	High Side Pressure:
Compressor Speed:	Low Side Pressure:	High Side Pressure:

Section 3: Humidity Sensor

1. What is the purpose of the humidity sensor?

2. Where is the humidity sensor located?

3. Is the humidity sensor located on the A/C Data List?

Section 4: A/C Data List

1. Select the A/C Data List using the Diagnostic Tester. Under User Data select EVAPORATOR TEMP, ROOM TEMP, HUMIDITY SENSOR, COMPRESSOR SPEED, and COMPRESSOR TARGET SPEED.
2. What is the relationship of the room temperature to the evaporator temperature when the A/C is OFF and then with the A/C ON?

3. What happens to the humidity sensor reading when the A/C is turned ON?

4. What happens to the compressor target speed when the humidity sensor and evaporator temperature sensor values drop?

Section 5: Customize Mode

1. The **Customize Mode** allows air conditioning functions to be modified to suit the customers needs. Modes are changed using the Diagnostic Tester.
2. With the Diagnostic Tester connected to DLC3, enter the **Customize Mode** located on the second screen after you turn the tester ON.
3. Select **Individual Change**. List at least three A/C climate control modes that can be customized.

Note: Return all cars to the original state and return to the classroom.



Notes



SELF-ASSESSMENT 6-1
Electric Air Conditioning System

Name:	Date:
-------	-------

Self-assessment Objectives

Review this sheet as you are doing the Electric Air Conditioning worksheet. Check off either category after completing the worksheet and instructor presentation. Ask the instructor if you have questions. The **Comments** section is for you to write notes on where to find the information, questions, etc.

I have questions

I know I can

Topic			Comment
Describe the electric A/C compressor.			
Describe the safety precautions of why ND11 oil must be used.			
List the safety precautions to be followed when servicing the A/C system.			
Access Active Test and select compressor speed.			
Locate the humidity sensor using TIS or the repair manual.			
View the A/C Data List.			
Locate and use Customize Mode for A/C.			



Notes

Appendix A

Acronym List

Acronym	Meaning
A/C	Air Conditioning
A/F	Air/Fuel Ratio
A/T	Automatic Transmission (Transaxle)
ABS	Anti-lock Brake System
AC	Alternating Current
ACC	Accessory
ALT	Alternator
AT - PZEV	Advanced Technology - Partial Zero Emissions Vehicle
AUX	Auxiliary
AVC-LAN	Audio Visual Communication - Local Area Network
AVG	Average
B	Regenerative Engine Braking
BA	Brake Assist
BATT	Battery
BEAN	Body Electronic Area Network
CAN	Controller Area Network
CB	Circuit Breaker
CCV	Canister Closed Valve
CO	Carbon Monoxide
CO2	Carbon Dioxide
COMB.	Combination
CV	Control Valve
D	Drive
DC	Direct Current
DEF	Defogger
DLC3	Data Link Connector 3
DOHC	Double Over Head Cam
DTC	Diagnostic Tester Code
DVOM	Digital Volt/Ohm Meter
EBD	Electronic Brake Distribution
ECM	Engine Control Module
ECU	Electronic Control Unit
ENG	Engine
EPA	Environmental Protection Agency
EPS	Electric Power Steering
ERG	Emergency Response Guide
ETCS-i	Electronic Throttle Control System w/ intelligence
EVAP	Evaporative Emission
FE	Fuel Economy
FL	Fusible Link
GND	Ground

Acronym	Meaning
GPS	Global Positioning Sensor
HC	Hydrocarbons
HCAC	Hydrocarbon Absorption Catalyst
H-Fuse	High Current Fuse
HV	High Voltage
IAC	Idle Air Control
IC	Integrated Circuit
IG	Ignition
INT	Instrument Panel
LED	Light Emitting Diode
LEV	Low Emissions Vehicle
LLC	Long Life Coolant
MAF	Mass Air Flow
MAX	Maximum
MG1	Motor Generator 1
MG2	Motor Generator 2
MIL	Malfunction Indicator Lamp
MIN	Minimum
N	Neutral
No.	Number
O ₂	Oxygen
OEM	Original Equipment Manufacturing
ORVR	On-board Recovery
P	Park
PCS	Power Control System
PS	Power Steering
PTC	Positive Temperature Coefficient
R	Reverse
RAM	Random Access Memory
RBS	Regenerative Brake System
RLY	Relay
SEN	Sensor
SFI	Sequential Multiport Fuel Injection
SLLC	Super Long Life Coolant
SMR	System Main Relay
SOC	State of Charge
SRS	Supplemental Restraint System
SST	Special Service Tool
SULEV	Super Ultra Low Emissions Vehicle
SW	Switch
TAS	Technical Assistant System
THS	Toyota Hybrid System

Acronym	Meaning
TIS	Toyota Information System
TPS	Throttle Position Sensor
TRAC	Traction Control System
TWC	Three Way Catalytic Converter
ULEV	Ultra Low Emissions Vehicle
V	Volts
VENT	Ventilator
VIM	Vehicle Interface Module
VIN	Vehicle Identification Number
VPS	Vapor Pressure Sensor
VSC	Vehicle Stability Control
VSV	Vacuum Switching Valve
VVT-i	Variable Valve Timing with Intelligence
WOT	Wide Open Throttle
ZEV	Zero Emissions Vehicle

Appendix B

Hybrid Vehicle Do's and Don'ts



DO NOT



DO

<p>DO NOT leave the key in the ON position with the vehicle OFF for an extended period of time. (The 12-Volt auxiliary battery will quickly discharge.)</p>	<p>DO turn the key OFF or leave the vehicle running (READY light ON) to avoid discharge of the 12-Volt battery.</p>
<p>DO NOT leave the auxiliary battery connected to the vehicle if it will be sitting for over three weeks.</p>	<p>DO disconnect the auxiliary battery if the vehicle will be sitting for over three weeks.</p>
<p>DO NOT charge the auxiliary battery with a regular battery charger.</p>	<p>DO pulse charge the auxiliary battery with Toyota's charger. (It must be recharged at a rate of no more than 3.5A or damage will occur.)</p>
<p>DO NOT tow the Prius with all four wheels on the ground. (Will create electricity.)</p>	<p>DO tow the Prius on a flat bed or with the front wheels off the ground.</p>
<p>DO NOT physically push the Prius around in the shop. (May create electricity.)</p>	<p>DO drive or move the vehicle on rollers when in the shop.</p>
<p>DO NOT shift into neutral with the READY light ON and let the vehicle sit. (High voltage battery cannot recharge in neutral.)</p>	<p>DO keep the vehicle in park.</p>
<p>DO NOT pull the service plug without wearing high-voltage insulated gloves.</p>	<p>DO wear high-voltage insulated gloves whenever working near high-voltage systems.</p>
<p>DO NOT change the oil until you have confirmed that the key is OFF.</p>	<p>DO turn the key OFF before an oil change. (Don't be fooled. You may not hear the engine running even though the car is ON! The engine will turn back ON!)</p>
<p>DO NOT get out of the car until you have confirmed it is in Park.</p>	<p>DO put the vehicle in Park before getting out. (Don't be fooled. You may not hear the engine running even though the car is ON! The car will drive away!)</p>
<p>DO NOT run the vehicle out of GAS! (The HV battery may have to be recharged at a dealership.)</p>	<p>DO turn the vehicle OFF immediately if you run out of gas. Once the vehicle has been refueled, the engine may be able to recharge the HV battery.</p>

Appendix C

Coolant Replacement Procedures

Caution

- The coolant in the coolant heat storage tank may be HOT even if the engine and radiator are cold.
- If the engine or radiator is hot, DO NOT remove the radiator cap.

Note:

- DO NOT drain coolant using the bolt on the bottom of the transaxle or tamper with the bleeder plug directly in front of the inverter assy, for a normal cooling system service.
- Use only Toyota SLLC. This coolant is pre-mixed - DO NOT add water!

Coolant Drain Procedure

1. Remove radiator top cover (6 plastic clips)
2. Remove the radiator cap
3. Pull down the front portion of the left front fender liner (Phillips screwdriver/ 10 mm wrench)
4. Disconnect coolant heat storage water pump connector (gray connector near top of tank)
5. Connect hoses to:
 - The drain port on the bottom of the coolant heat storage tank
 - The drain port on the rear side of the lower left corner of the radiator
 - The engine coolant drain port on the rear side of the engine
6. Loosen the yellow drain plug on the coolant heat storage tank to drain coolant
7. Loosen the yellow drain plug on the radiator to drain coolant
8. Use a 10 mm wrench to loosen the drain plug on the back of the engine
9. After coolant has drained, tighten all three plugs (torque engine port to 9.6 ft/lb)
10. Reconnect coolant heat storage water pump connector reinstall left front fender liner

Coolant Fill Procedure

- Connect a hose to the radiator bleeder valve port (located next to yellow label on radiator bulkhead) and place the other end of the hose in the reservoir tank
- Using a 6 mm hex wrench, loosen the radiator bleeder plug 3 turns
- Fill the radiator with coolant
- Tighten the radiator bleeder plug (13 in./lb) and install the radiator cap
- Connect the Diagnostic Tester to DLC3
- Operate the coolant heat storage system pump for 30 seconds
- Loosen the radiator bleeder plug 3 turns
- Remove the radiator cap and top off the radiator with coolant
- Repeat steps 4 through 8 until the system is full
- Start the engine for 1 -2 minutes
- Stop the engine, remove the radiator cap and top off the radiator with coolant
- Install the radiator cap and warm-up the engine (inspection mode)
- Cool down the engine
- Top off the coolant
- Repeat steps 12 to 14 until the system is full

High Voltage Warning Card

Person in charge: _____

**CAUTION:
HIGH VOLTAGE. DO
NOT TOUCH DURING
OPERATION.**

**CAUTION:
HIGH VOLTAGE. DO
NOT TOUCH DURING
OPERATION.**

Person in charge: _____